

## IT83 Series Indoor Monitor Admin Guide

## About This Manual

Thank you for choosing Akuvox's IT83 series indoor monitor. This manual is intended for end users, who need to use and configure the indoor monitor. This manual provides an introduction of all functions and features of the product. It is suitable for 83.31.2.3xx version. Please visit Akuvox forum or consult technical support for any new information or latest firmware.

**Note:** Please refer to universal abbreviation form in the end of manual when meet any abbreviation letter.

# Content

<b>1. Product Overview .....</b>	<b>1</b>
1.1. Product Description.....	1
1.2. Connector Introduction.....	2
<b>2. Daily Use .....</b>	<b>3</b>
2.1. Starting.....	3
2.2. Making a Call .....	5
2.2.1. Calling from Call List.....	5
2.2.2. Calling from All Call.....	5
2.2.3. Calling from Missed Call .....	6
2.2.4. Calling from Device.....	7
2.2.5. Calling from LocalPhoneBook .....	7
2.2.6. Calling from Keypad .....	8
2.3. Receiving a Call .....	8
2.3.1. Receive an Incoming Call .....	8
2.3.2. During the session .....	9
2.4. Monitor .....	9

2.4.1. Checking the Monitor .....	10
2.5. Message.....	11
2.5.1. Text Message.....	11
2.5.2. Creating a Message.....	12
2.5.3. Deleting a Message .....	13
2.6. Arming.....	14
2.6.1. Arming Mode .....	14
2.6.2. Disarm Code .....	15
2.6.3. Alarm Log .....	16
2.6.4. Status.....	16
<b>3. Basic Features .....</b>	<b>17</b>
3.1. Accessing the System Settings.....	17
3.1.1. Advanced System Setting.....	17
3.2. Accessing the Website Setting.....	17
3.2.1. Obtaining IP address .....	17
3.2.2. Accessing the Device Website.....	18
3.3. Password Modification .....	18



3.3.1. System Code Modification .....	18
3.3.2. Setting Code Modification .....	19
3.3.3. Web Password Modification.....	19
3.4. Phone Configuration .....	20
3.4.1. Language .....	20
3.4.2. Time .....	20
3.4.3. Network.....	22
3.4.3.1. Network Status .....	22
3.4.3.2. Network Settings .....	23
3.4.3.3. WIFI Setting (optional).....	24
3.4.3.4. Local RTP .....	24
3.4.4. Bluetooth (optional).....	24
3.4.4.1. Turning Bluetooth On /Off.....	25
3.4.4.2. Changing Bluetooth Device Name .....	25
3.4.4.3. Paring With Another Bluetooth Device .....	26
3.4.4.4. Transfer By bluetooth .....	26
3.4.4.5. Unparing the Bluetooth Device.....	26

3.4.5. Display Settings .....	27
3.4.6. Sound Settings .....	28
3.4.7. Door Bell Sound.....	28
3.4.8. DND .....	29
3.4.9. Capture .....	30
3.4.10. Logo .....	30
3.4.11. Key Set of IT83X Monitor .....	31
3.5. Local PhoneBook .....	32
3.5.1. Adding a Contact .....	32
3.5.2. Editing a Contact .....	33
3.5.3. Contact Import/Export .....	34
3.5.4. Black List .....	34
3.6. Intercom Call .....	36
3.6.1. IP Direct Call .....	36
3.6.2. SIP Call .....	36
3.6.3. Account Status.....	37
3.6.4. SIP Account .....	38

3.6.5. SIP Server.....	39
3.6.6. Outbound Proxy Server .....	39
3.6.7. Transport Type.....	40
3.6.8. Auto answer.....	40
3.6.9. Assistance call .....	41
3.6.10. Multicast.....	42
3.7. Security .....	43
3.7.1. Monitor Settings.....	43
3.8. Access control.....	45
3.8.1. Face ID .....	45
3.8.2. Local Relay .....	45
3.8.3. Remote relay .....	46
3.8.4. Reboot .....	47
3.8.5. Reset .....	47
<b>4. Advanced Features .....</b>	<b>48</b>
4.1. Phone Configuration .....	48
4.1.1. Installing Custom APK .....	48

4.1.2. Discovery setting .....	50
4.2. Intercom .....	51
4.2.1. Call Forwarding.....	51
4.2.2. Intercom .....	52
4.2.3. Subscribe .....	52
4.2.4. Audio Codec .....	53
4.2.5. Video Codec .....	53
4.2.6. NAT .....	54
4.2.7. User Agent .....	54
4.2.8. DTMF .....	55
4.2.9. Encryption .....	55
4.2.10. Call Related .....	56
4.2.11. Remote Control .....	56
4.2.12. Session Time Out .....	57
4.3. Access Control.....	57
4.3.1. Web Relay .....	57
4.3.2. Remote Relay by HTTP .....	58

4.4. Security .....	58
4.4.1. Arming Zone Setting .....	58
4.4.2. Motion Detector .....	59
4.5. Upgrade .....	60
4.5.1. Basic Upgrade .....	60
4.5.2. Autop .....	61
4.5.2.1. PNP Autop .....	61
4.5.2.2. DHCP Autop .....	62
4.5.2.3. Manual Autop.....	62
4.5.2.4. Automatic Autop.....	63
4.6. Logs .....	64
4.6.1. Call log.....	64
4.6.2. System Log.....	64
4.6.3. PCAP .....	65

# 1. Product Overview

## 1.1. Product Description

IT83X is an Android SIP-based with smooth touch-screen indoor monitor. It can be connected with Akuvox door phone for audio/video communication, unlocking and monitoring.

Residents can communicate with visitors via audio/video call, and it supports to unlock the door remotely. It is more convenient and safer for residents to check the visitor's identity through its video preview function.

IT83X are often applied to scenarios such as villas, apartments and buildings.

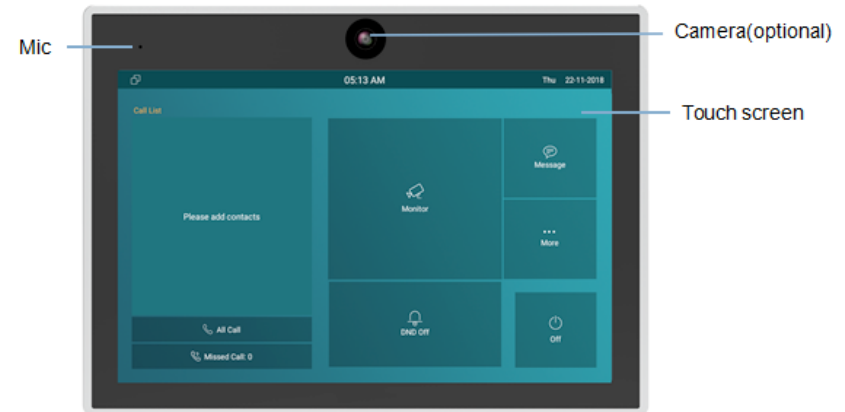

## 1.2. Connector Introduction

**Ethernet (POE):** Ethernet (POE) connector which it can provide both power and network connection.

**RJ45 (PON):** Share the network access from Ethernet (POE) port, and for PC and other equipments connection.

**12V/GND:** External power supply terminal if POE is not available.

**RS485A/B:** RS485 terminal.

**Bell/GND:** Connect a simple two-wire door bell.

**Relay A/B (NO/COM/NC):** Relay control terminal.

**IO1- IO8/GND:** Connect with different alarm detectors for 8 security zones.

**Note:** The general indoor monitor interface diagram is only for reference.

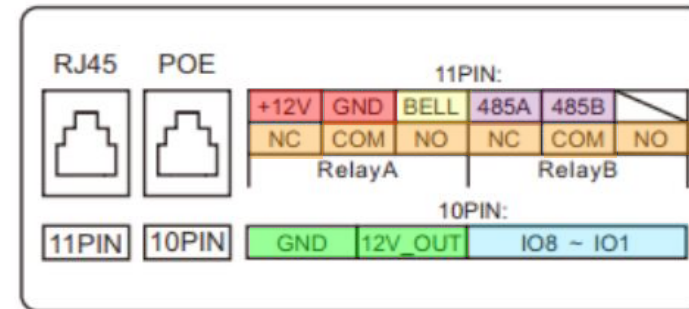

Figure 1.2-1 IT83X interface

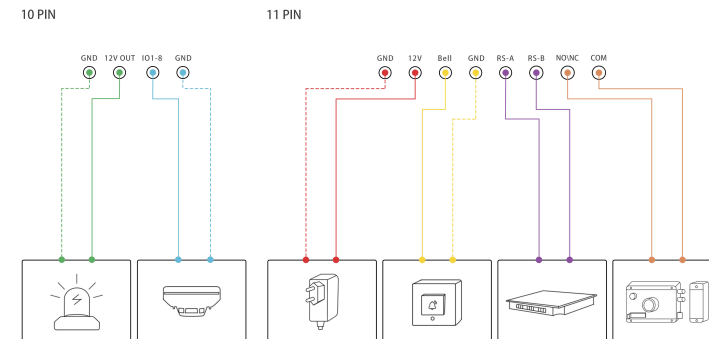

Figure 1.2-2 General interface

## 2. Daily Use

### 2.1. Starting

When booting IT83X first time, users need to choose a suitable way to connect to network, wireless or wire.

To choose a proper device mode according to specific application scenarios. IT83X supports 3 modes, including **Cloud**, **Discovery** and **SDMC**. It only pop up Cloud Mode and Discovery Mode for users choosing. Tap **Skip** if users are adopting SDMC mode. Discovery mode is default mode if you don't choose any device mode.

**Discovery mode:** It is a plug and play configuration mode. Akuvox devices will configure themselves automatically when users power on the devices and connect them to network. It is super time-saving mode and it will greatly bring users convenience by reducing

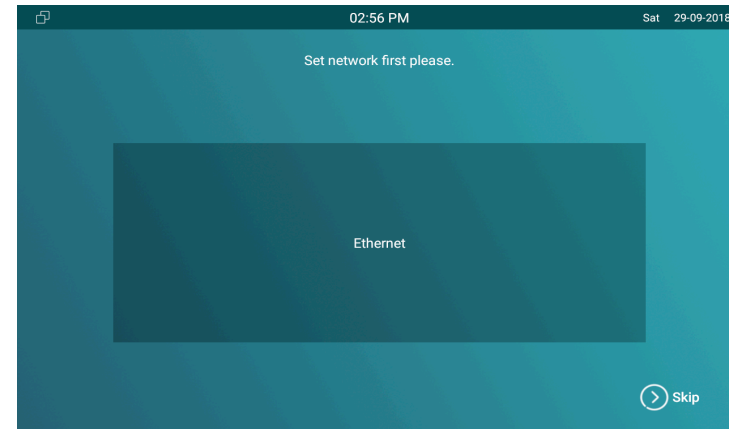

Figure 2.1-1 Network selection

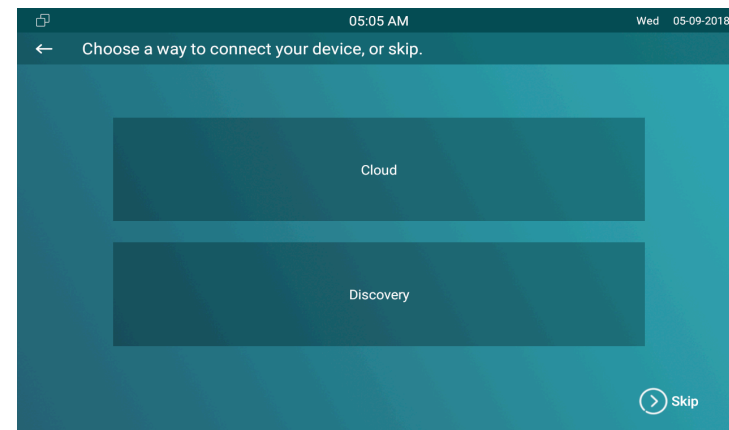

Figure 2.1-2 Device mode selection



manual operations. This mode do not need to be done any configurations previously by the administrator.

**Cloud mode:** Akuvox Cloud is an all in one management system. Akuvox Cloud is the mobile service that allows audio, video, remote access control between smart phones and Akuvox intercoms. All configurations in the device will be issued automatically from cloud. If users decide to use Akuvox cloud, please contact administrator, who will help to configure related settings before using.

**SDMC mode:** SDMC is a center management software which is suitable for managing a community in LAN. The device will get settings from SDMC automatically.

## 2.2. Making a Call

There are 6 ways to establish VOIP calls by IT83X.

### 2.2.1. Calling from Call List

In the home page, choose a number from **Call List** to make a call.

- Scroll up or down the **Call List** to choose the contact that users want to call.

**Note:** In Cloud or SDMC mode, the **Call List** of IT83X will be issued from the system.

### 2.2.2. Calling from All Call

In the home page, it could call multiple indoor monitors if they are set under the same multicast address. During the session, IT83X is listened by other indoor monitors.

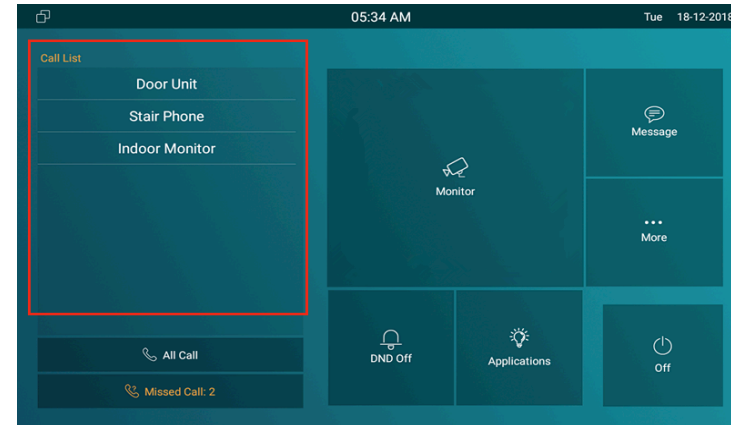

Figure 2.2.1-1 Call from call list

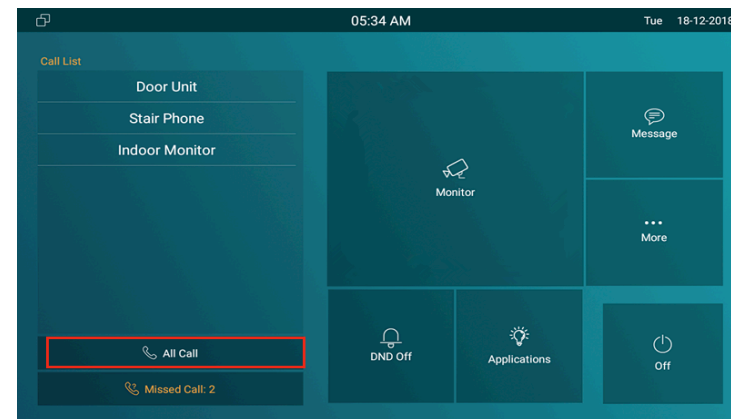

Figure 2.2.2-1 Call from all call

- Tap **All Call** icon to call other indoor monitors which are set in the same multicast group.

### 2.2.3. Calling from Missed Call

In the home page, missed call indicates how many calls that users missed (1 missed call for an example). Missed call could be treated as a brief call log.

- Tap **Missed Call** icon ① to view the calls that were not answered before.
- Choose the contact on the call list ② which users want to call out.
- Click account above the keypad ③ to switch accounts to make a call.
- Choose **Audio** ④ or **Video** ⑤ mode to call out.

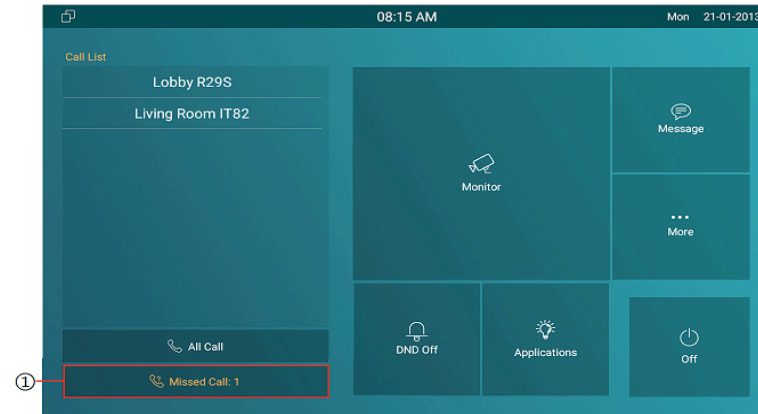

Figure 2.2.3-1 Call from miss call

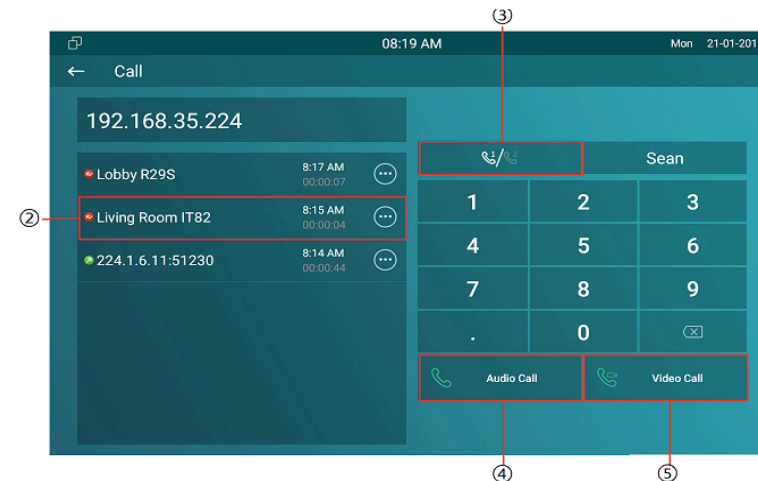

Figure 2.2.3-2 Call from miss call

## 2.2.4. Calling from Device

It will display the devices connected with IT83X on the contact interface. On the device, go to **More - Contact**.

- Click **Update** ① to synchronous the contact automatically.
- Choose a device ② which users want to call.
- Choose **Audio** ③ or **Video** ④ mode to call out.

**Note:** Only under Discovery mode, users need to press **Update** key manually.

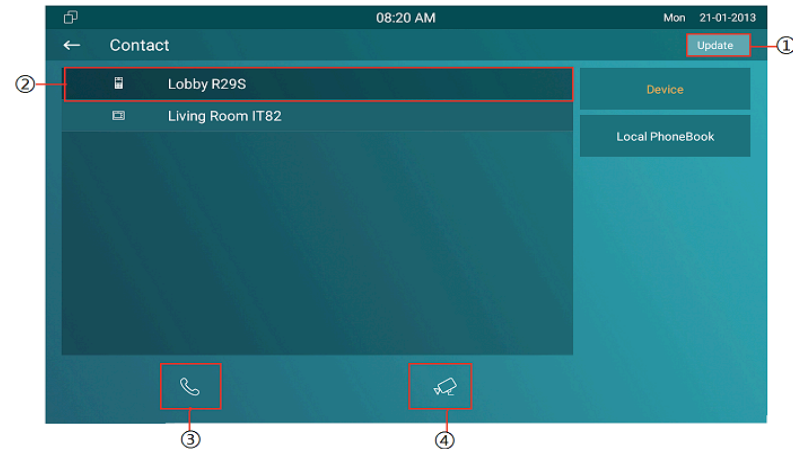

Figure 2.2.4-1 Call from device

## 2.2.5. Calling from LocalPhoneBook

On the device, go to **More - Contact** to enter the **Local PhoneBook** interface to make a call.

- IT83X supports fuzzy matching query ① To search the list by entering number or alphabet.
- Scroll up or down to select contact ② that users want to call.

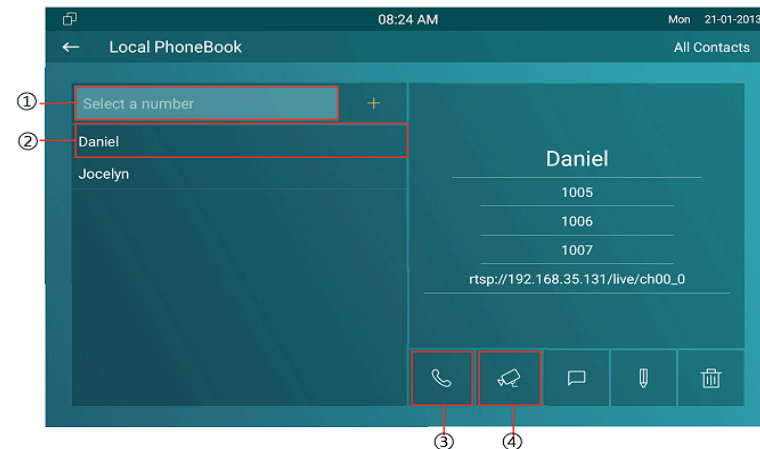

Figure 2.2.5-1 Call from local phonebook

- Choose **Audio** ③ or **Video** ④ mode to call out.

## 2.2.6. Calling from Keypad

On the device, go to **More - Call** to get access to keypad.

- Click account icon ① above the keypad to switch accounts to make a call.
- Input the SIP account /IP address to the keypad ② to call the corresponding devices or soft phone.
- Choose **Audio** ③ or **Video** ④ mode to call out.

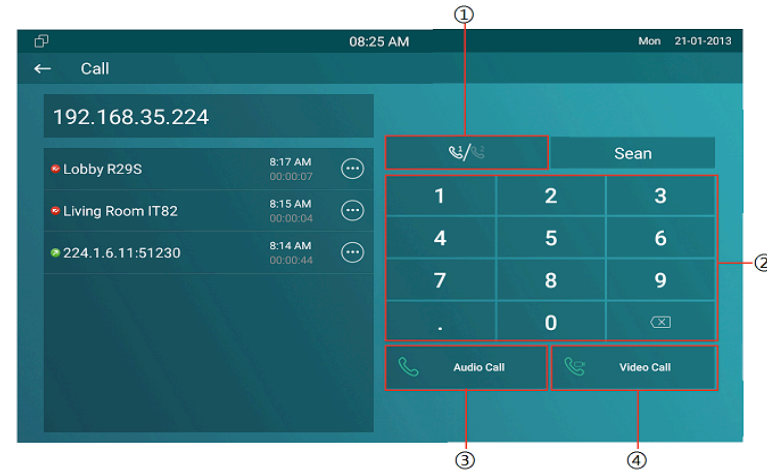

Figure 2.2.6-1 Call from keypad

## 2.3. Receiving a Call

### 2.3.1. Receive an Incoming Call

IT83X supports to preview the caller when it receives an incoming call from door phone.

- Tap **Answer** to pick up the incoming call.

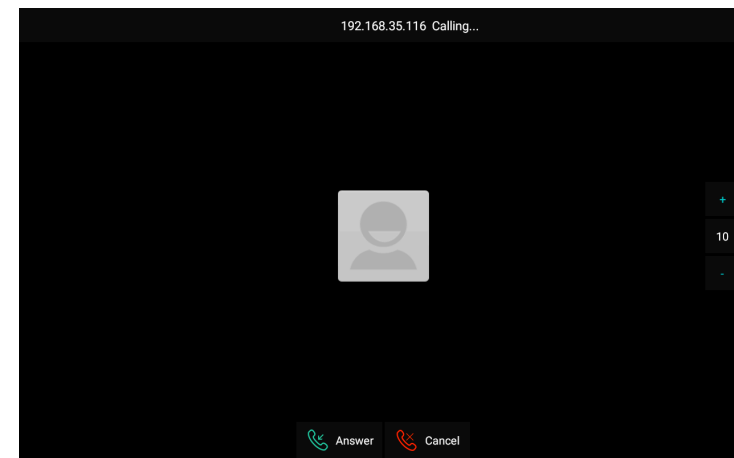

Figure 2.3.1-1 Incoming call

- Tap **Cancel** to reject the incoming call. Press “+” or “-” of the volume on the right side to adjust the ring tone volume.

### 2.3.2. During the session

- Tap **Unlock** to open the corresponding door (if the call is from outdoor unit).
- Tap **Capture** to take a screen shot of current interface.
- Tap **Mute** to eliminate the voice on IT83X’s side.
- Tap **Switch** to switch from video call to audio call or vice versa.
- Tap **Cancel** to hang up the current call.

## 2.4. Monitor

Monitor feature enables users to view the real-time video from IP cameras or door phones anytime. Click **Monitor** in the home page.

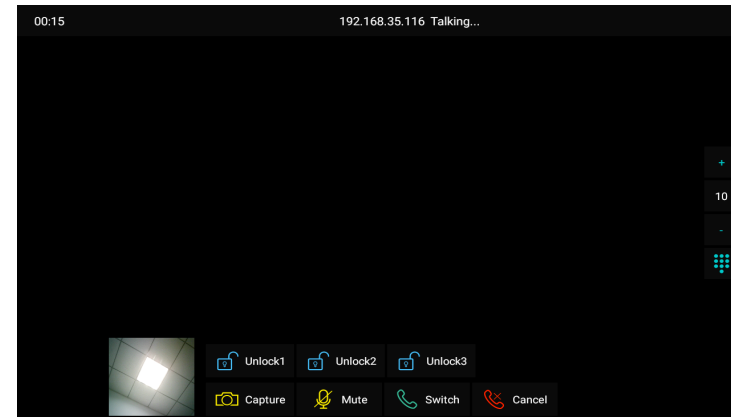

Figure 2.3.2-1 During session

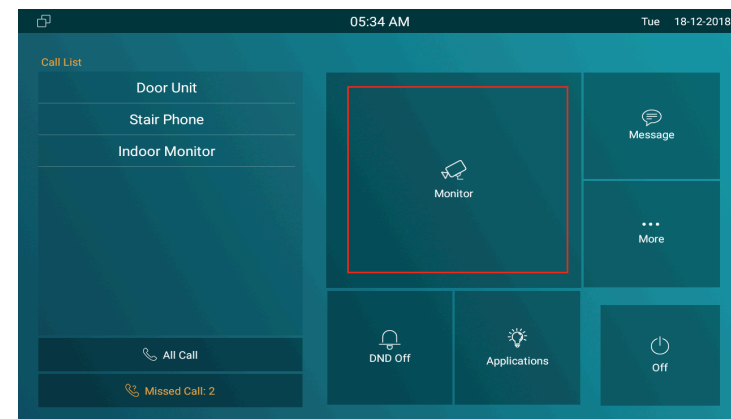

Figure 2.4-1 Monitor

## 2.4.1. Checking the Monitor

Choose the outdoor devices from the list. The real-time video from the door phone or IP camera will show in the screen .

- Press **Unlock** to open the door which is connected with door phone.
- Press **Capture** to take a screen shot of current interface.
- Press **Cancel** to exit the monitoring.
- Press **List button** in the bottom right corner to wake the outdoor video list.
- Press the **Monitor list** in the right side to choose the outdoor videos.

**Note:** Only under Discovery mode, users need to press **Update** key manually to synchronous the devices which is in the same node.

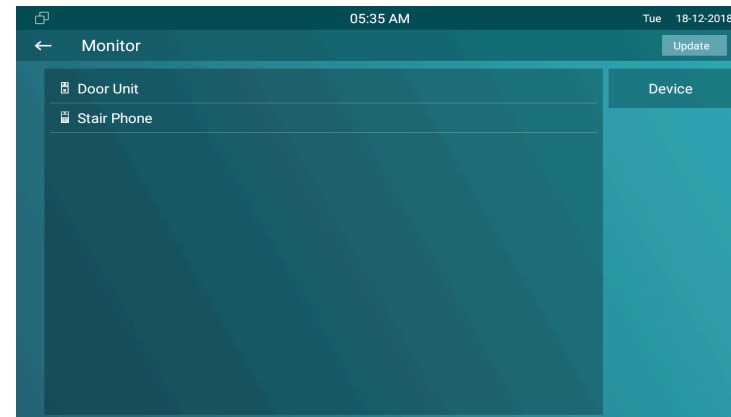

Figure 2.4.1-1 Live view list

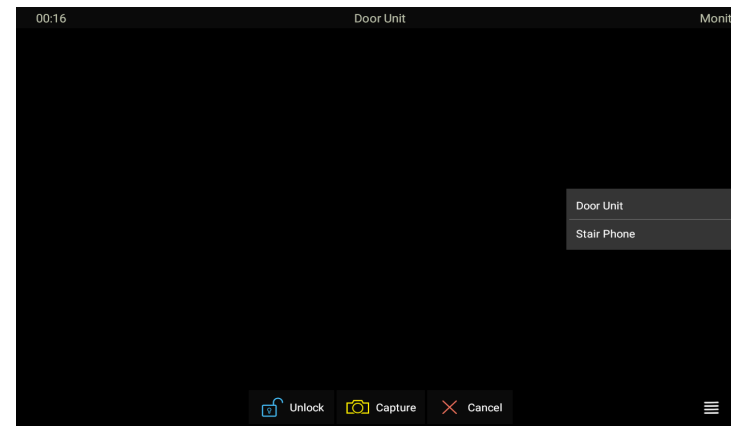

Figure 2.4.1-2 Live view video

## 2.5. Message

**Message** ① indicates how many messages are unread ( An unread message for an example). Or directly enter the message interface to manage.

### 2.5.1. Text Message

- Tap **Message** ① on the main interface to view the unread message.
- Tap the unread message ② to view the message in details.

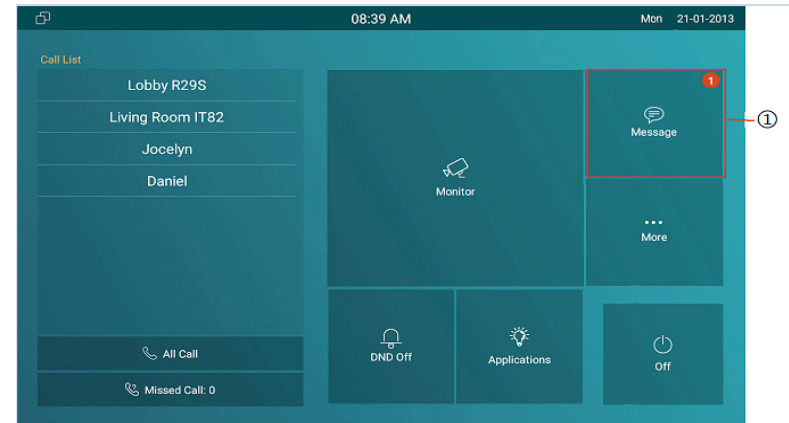

Figure 2.5 -1 Message

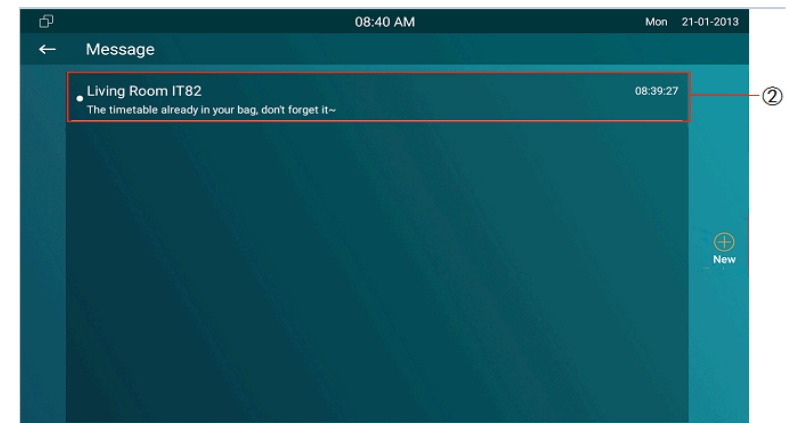

Figure 2.5.1-1 Text message



## 2.5.2. Creating a Message

- Press **New** key ① to create a new message.
- Enter the destination number manually ② or choose the contact from the **contact list** ③ or select the device quickly from the below list ④ .
- Choose the **frequently used message** ⑤ , such as “Hello,” “Help.” Or input the message content which users want to send ⑥.
- Press **Send** key ⑦ to send.

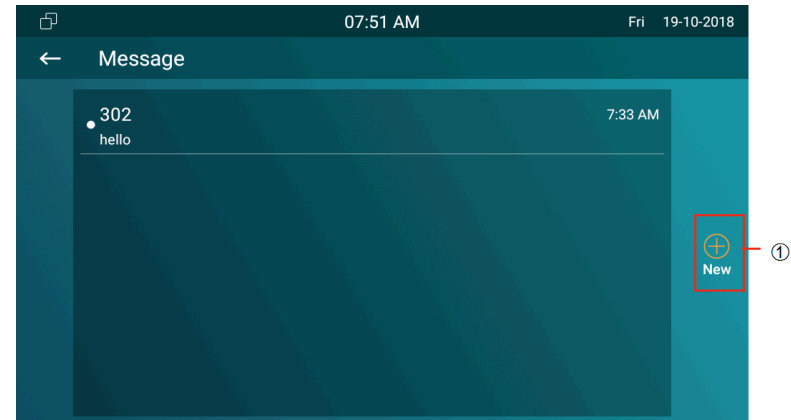

Figure 2.5.2-1 Create message

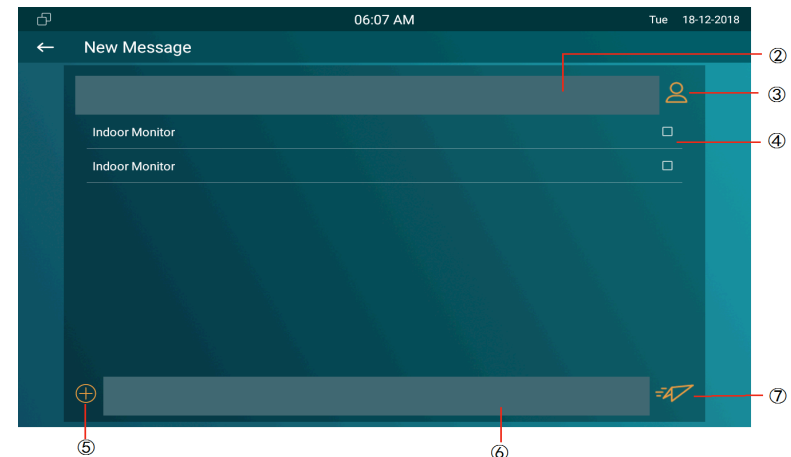

Figure 2.5.2-2 Create message

## 2.5.3. Deleting a Message

- Long press the message ① to select it.
- Click **Select All** ② to select all message in the message lists.
- Click **Delete** ③ to delete the messages have been selected.
- Click **Cancel** ④ to cancel the operation.
- Click **Back** icon ⑤ to exit the message interface.



Figure 2.4.2-1 Delete message

## 2.6. Arming

Tap **Arming** to enter the Arming interface. Arming feature is not displayed by default. Users can ask administrator to enable it. Please refer to chapter 3.4.10.

IT83X supports 4 modes, including **Home** mode, **Night** mode, **Away** mode and **Disarmed** mode.

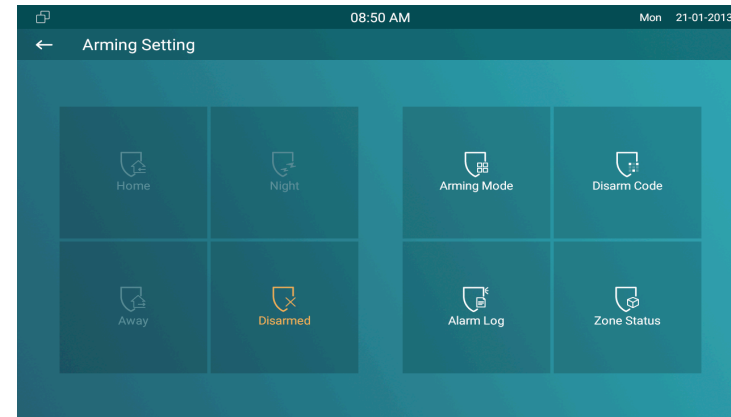

Figure 2.6-1 Arming

### 2.6.1. Arming Mode

Go to **Arming - Arming mode**. Users can see all of the 8 zones and corresponding sensor types. Slide down to check more information in this interface.

- Adjust **Defence delay time**. It means when users change the arming mode from other modes, there will be 90 seconds delay time to get activated.
- To setup the **Alarm delay**. It means when the sensor triggered,

Arming Mode					
Home		Night		Away	
Zone	Location	Zone Type	Defence delay	Alarm Delay	Status
Zone1	Guest room	Doorbell	90s delay	90s delay	24H
Zone2	Bedroom	Infrared	90s delay	90s delay	Disable
Zone3	Bedroom	Infrared	90s delay	90s delay	Disable
Zone4	Bedroom	Infrared	90s delay	90s delay	Disable
Zone5	Bedroom	Infrared	90s delay	90s delay	Disable
Zone6	Bedroom	Infrared	90s delay	90s delay	Disable
Zone7	Bedroom	Infrared	90s delay	90s delay	Disable
Zone8	Bedroom	Infrared	90s delay	90s delay	Disable

Figure 2.6.1-1 Arming mode

there will be 90 seconds delay time to announce the notification.

- The **Status** in the corresponding zone means whether the zone is available or not.
- Press **Save** in the top right corner to save the modification.

## 2.6.2. Disarm Code

Go to **Arming - Disarm Code** to enter the disarm code settings interface. Users can modify the disarm code here.

- Enter the **original disarm code** ① first, and it is 0000 by default.
- Enter the **new disarm code** ②.
- Enter the new disarm code again ③ for confirming.
- Press **Save** to save the modification.

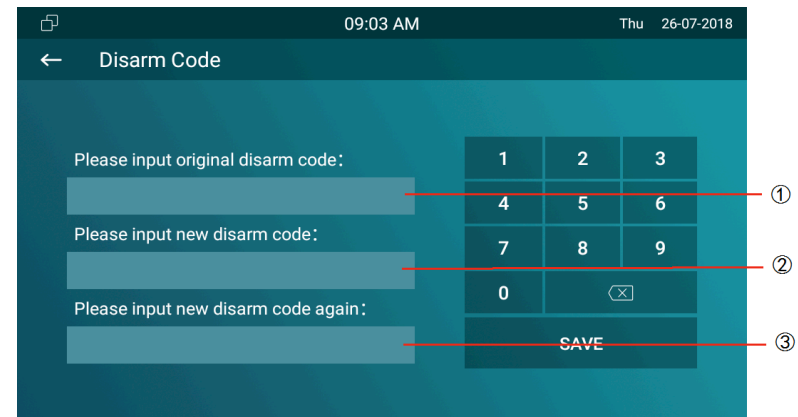

Figure 2.6.2-1 Disarm code

### 2.6.3. Alarm Log

Go to **Arming - Alarm Log** to enter the alarm log interface. Users can check the alarm log, including “location,” “zone,” “zone type” and “alarm time.”

- Hold an **alarm log** ① and it will show up delete prompt.
- Press **Select All** ② to delete all alarm log or select a part of existed messages then click **Delete** ③.
- Press **Cancel** ④ to cancel to deletion.

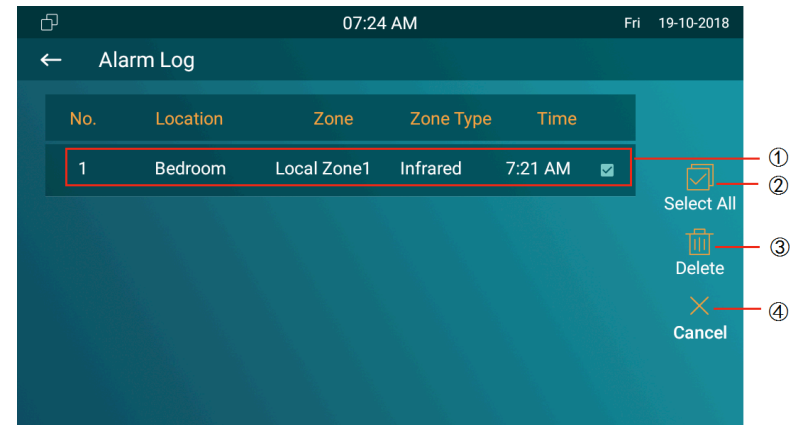

Figure 2.6.3-1 Alarm log

### 2.6.4. Status

Go to **Arming - Zone Status** to enter the zone status interface. Users can check the status of zones, including “location,” “zone type,” “trigger mode” and “status.”

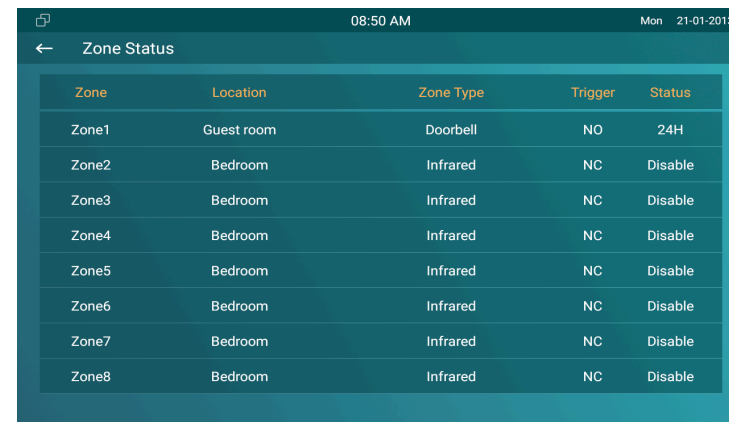

Figure 2.6.4-1 Alarm status

## 3. Basic Features

### 3.1. Accessing the System Settings

#### 3.1.1. Advanced System Setting

On the device, go to **More - Settings - More** (Default password is 123456) to access advanced system settings.

The latter **More** interface have more advanced features' settings.

### 3.2. Accessing the Website Setting

#### 3.2.1. Obtaining IP address

On the device, go to **More - System Info - Network** to check the device's IP address.

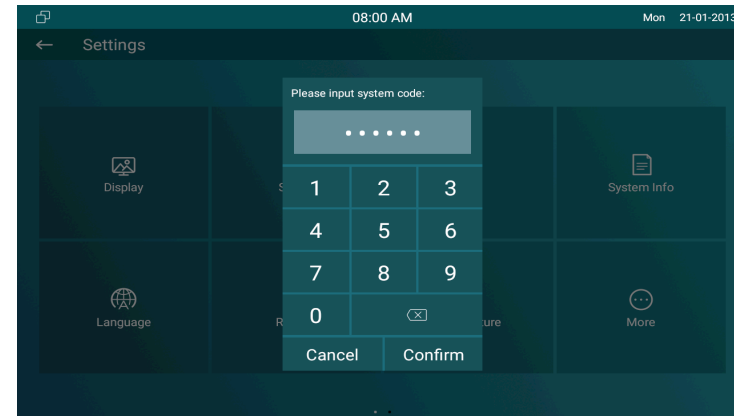

Figure 3.1-1 System setting

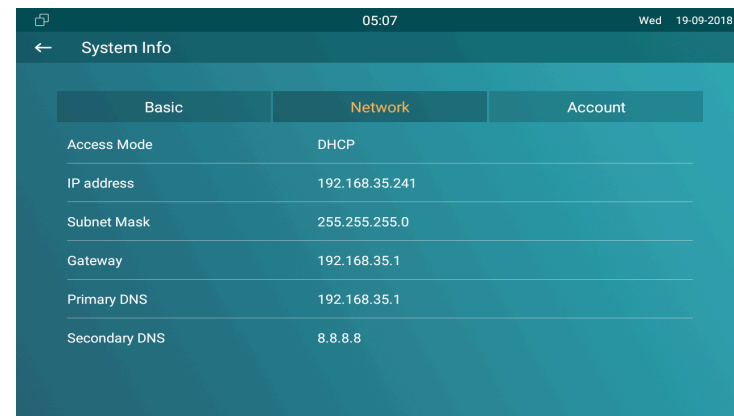

Figure 3.2.2-1 Network status

### 3.2.2. Accessing the Device Website

Type the device's IP address on browser, and input default user name and password: **admin /admin** to access the web interface.

**Note:** The recommended browser is Google Chrome.

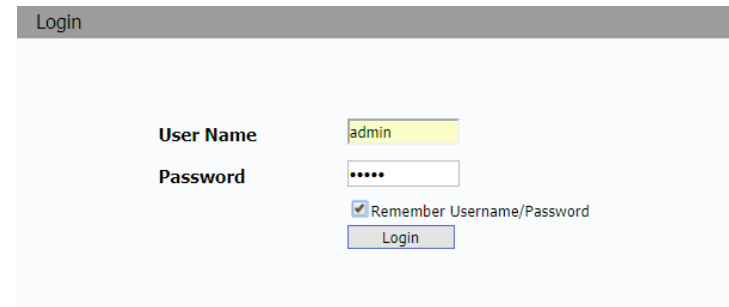

Figure3.2.2-2 Login web

## 3.3. Password Modification

### 3.3.1. System Code Modification

On the device, go to **More - Settings - More - System Code**.

System code is used to enter higher level **More** interface, and the **original system code** ① is 123456. Administrator can edit a **new system code** ② to prevent someone from tampering with the advanced configurations, and then confirm the new one ③ and click submit ④ to save.

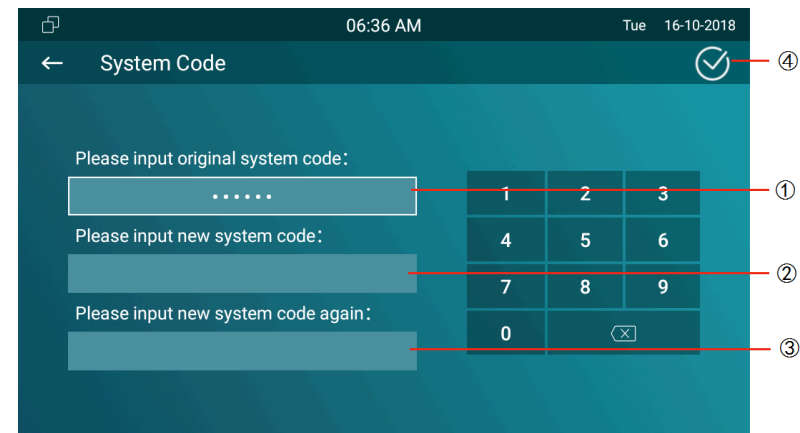

Figure3.3.1-1 System code

### 3.3.2. Setting Code Modification

On the device, go to **More - Settings - More - Setting Code**.

Setting code is used to enter “Setting interface,” and the **original setting code** ① is null. Administrator can edit a **new setting code** ② to prevent someone from entering the setting interface, and then confirm the new one ③ and click submit ④ to save.

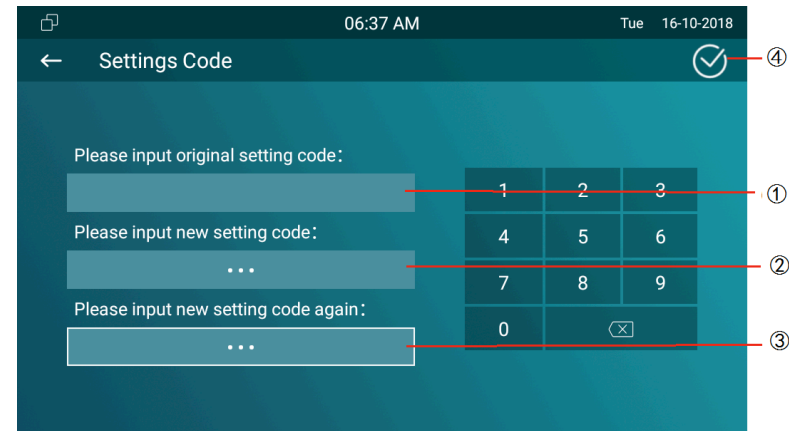

Figure 3.3.2-1 Setting code

### 3.3.3. Web Password Modification

Access the website, go to **Security - Basic** to modify the default website password “admin.” Enter the original password and new password, and confirm the new password again.

**Confirm Password:** To enter the new password again to confirm there is no mistake.

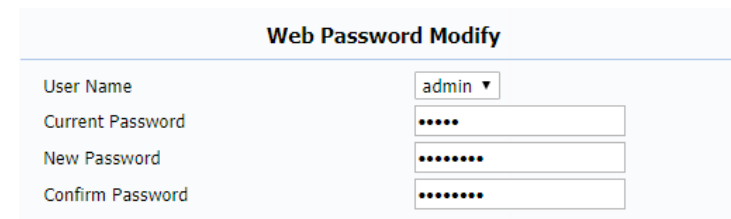

Figure 3.3.3-1 Web Password



## 3.4. Phone Configuration

### 3.4.1. Language

On the device, go to **More - Settings - Language** to choose a suitable phone screen display language, and it is English by default. In the website, go to **Phone - Time/Lang** to select a web language, and it is English by default.



Figure 3.4.1-1 Phone language

### 3.4.2. Time

On the device, go to **More - Settings - Time** to enter the time setting interface.

**Automatic Date Time:** Tick to enable NTP server.

**Set Date:** To set the date manually.

**Set Time:** To set the time manually.

**Time Zone:** To select which time zone user is in.

**Use 24-Hour Format:** To enable 24 hours format for a day.

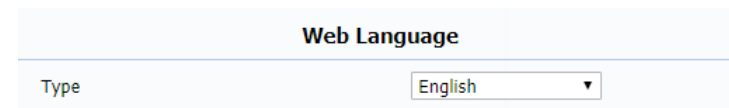

Figure 3.4.1-2 Web language

**Date Format:** To select different date format.

**NTP Server:** To fill in the NTP server to get time automatically.

On the web portal, go to **Phone - Time/Lang**.

**Time Zone:** To select which time zone user is in.

**Primary Server:** To fill in NTP server to get time automatically.

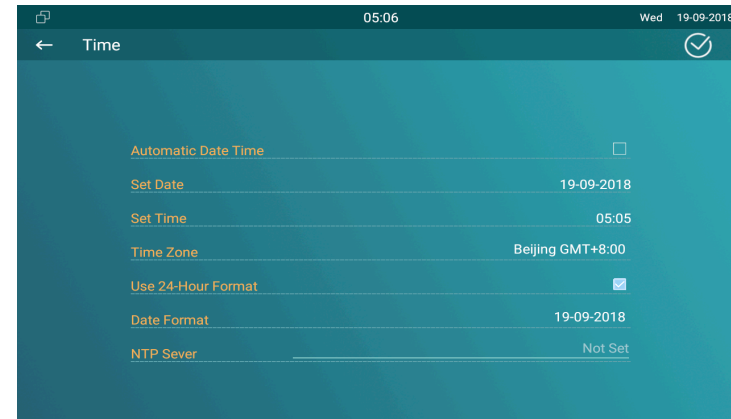

Figure 3.4.2-1 Time setting



Figure 3.4.2-2 NTP setting

### 3.4.3. Network

#### 3.4.3.1. Network Status

On the device, go to **More - System Info - Network**.

Users could check the basic network status from this interface, including access mode, IP address parameters and so on.

On the web portal, go to **Status - Basic - Network Information** to check network information.

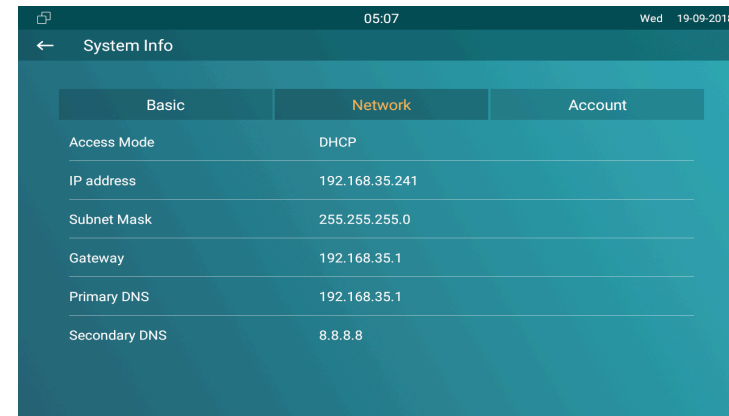

Figure3.4.3.1-1 Network info

Network Information	
LAN Port Type	DHCP Auto
LAN Link Status	Connected
LAN IP Address	192.168.35.30
LAN Subnet Mask	255.255.255.0
LAN Gateway	192.168.35.1
LAN DNS1	192.168.35.1
LAN DNS2	

Figure3.4.3.1-2 Web network info

### 3.4.3.2. Network Settings

On the device, go to **More - Settings - More - Network**.

**DHCP:** Tick the DHCP option to configure the network as DHCP mode, and then IT83X will obtain the IP address, and other network parameters automatically.

**Static IP:** Fill in the parameters of LAN IP, subnet mask, gateway, pri DNS server and sec DNS server manually.

On the web portal, go to **Network - Basic** to configure the network settings.

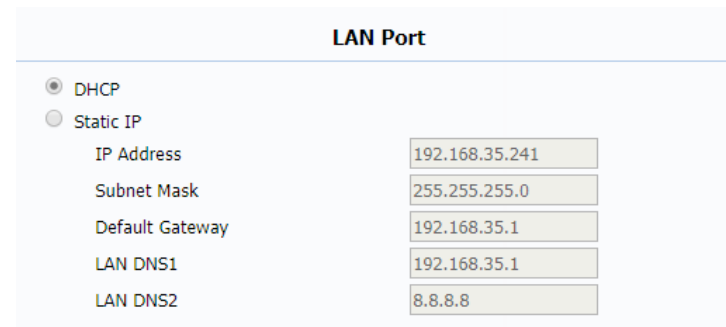
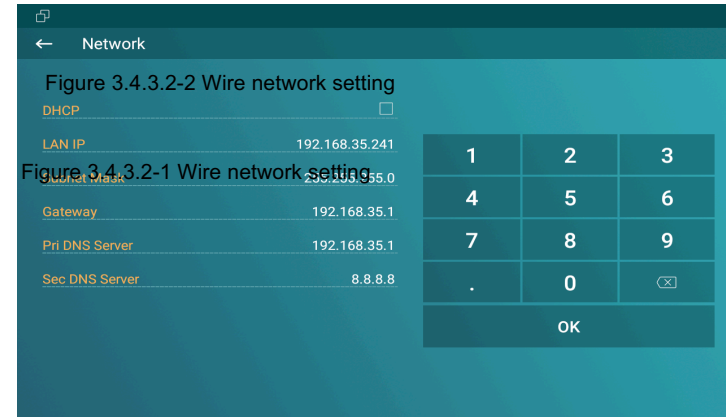

### 3.4.3.3. WIFI Setting (optional)

On the device, go to **More - Settings - More - WiFi** to enable the WIFI feature, choose the suitable AP (Access point), and then enter the password to connect to it.

### 3.4.3.4. Local RTP

On the web portal, go to **Network - Advanced - Local RTP**.

**Starting RTP Port:** To determine the minimum port for RTP stream.

**Max RTP Port:** To determine the maximum port for RTP stream.

### 3.4.4. Bluetooth (optional)

Bluetooth is a proprietary, open wireless technology standard for exchanging data over short distances from fixed and mobile devices, and creating personal area networks with high levels of

Figure 3.4.3.3-1 RTP setting

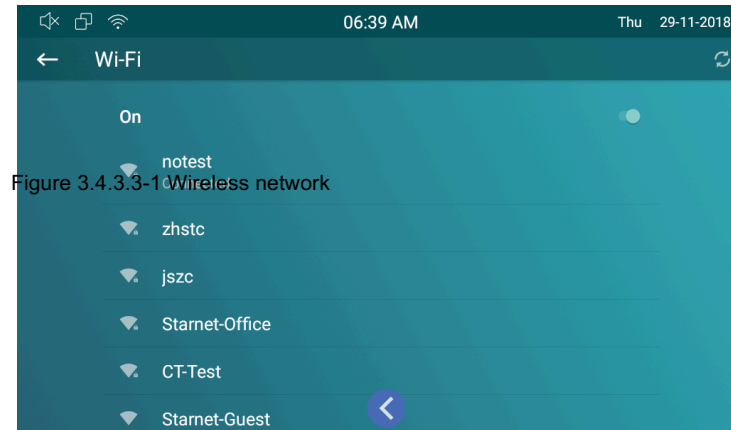

Local RTP		
Starting RTP Port	<input type="text" value="11800"/>	(1024~65535)
Max RTP Port	<input type="text" value="12000"/>	(1024~65535)

security.

### 3.4.4.1. Turning Bluetooth On /Off

In the device, go to the More - Settings -Bluetooth, click On to enable the bluetooth.

### 3.4.4.2. Changing Bluetooth Device Name

The IT83A/W uses “rk312x” as Bluetooth device name by default. The device name will be visible to other devices when connecting them. In the device, click top right corner ,choose “Rename this device” to modify the device name, click **RENAME** to save.

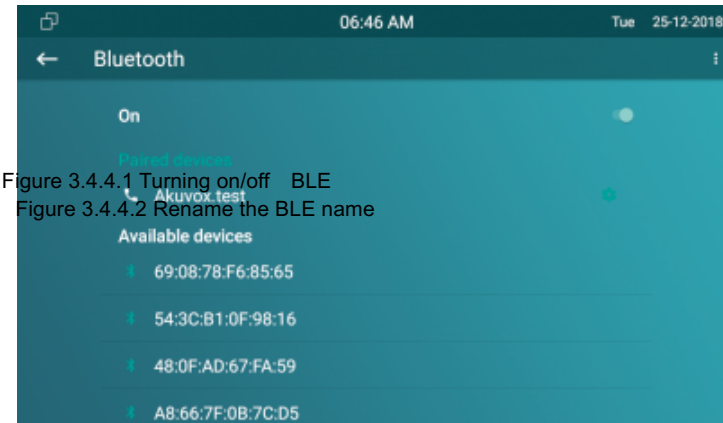
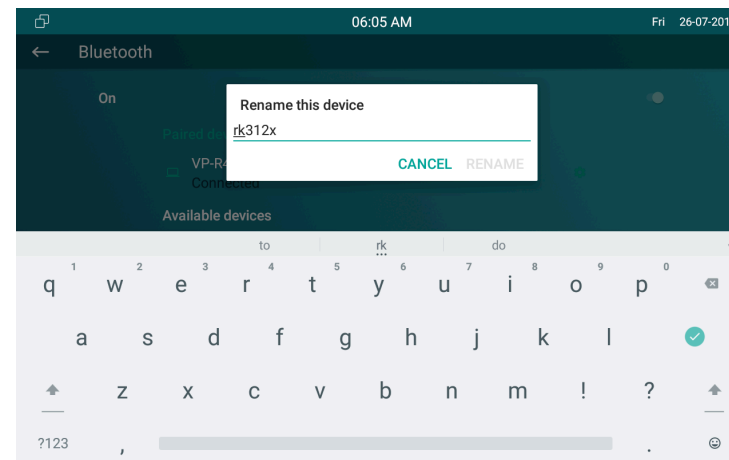

Figure 3.4.4.1 Turning on/off BLE  
Figure 3.4.4.2 Rename the BLE name



### 3.4.4.3. Paring With Another Bluetooth Device

After enable bluetooth, the available devices will be shown in the list. If you want to refresh the device list, click top right corner to Refresh.

- Choose which one you need to connect,
- Click PAIR in the prompt windows in both sides.
- The Device will be connected successfully.

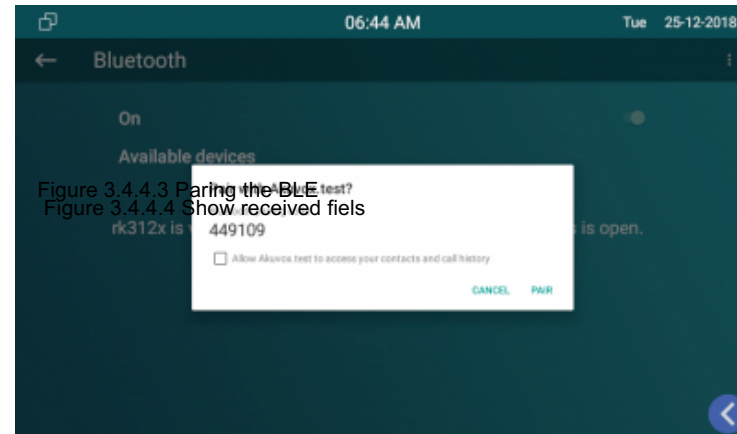

### 3.4.4.4. Transfer By bluetooth

After connection, users can choose bluetooth to transfer and receive some files. And user can check the received file in the top right corner "Show received files".

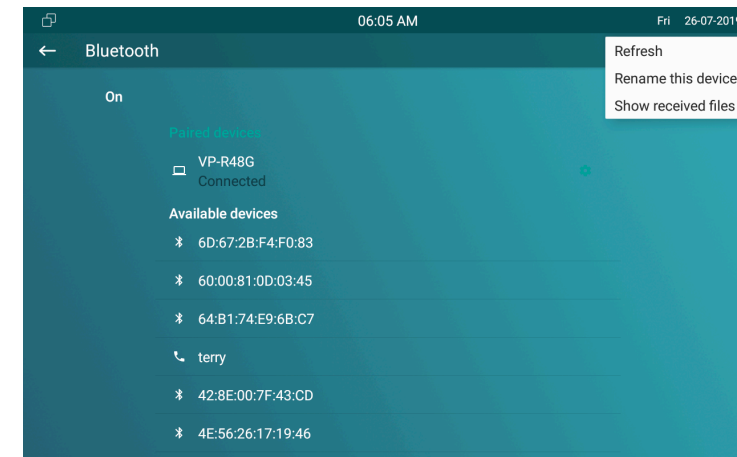

### 3.4.4.5. Unparing the Bluetooth Device

- Click the connected device.

- Click OK in the prompt windows.
- The Device will be disconnected successfully.

### 3.4.5. Display Settings

On the device, go to **More - Settings - Display**.

**Brightness:** To adjust the brightness which is 145 by default. The range is from 0 to 255. The bigger value means the brighter screen.

**Sleep:** To configure the sleep delay which is 1 minute by default. If there is no any operation in 1 minute, it will turn to sleep screen.

**Screen Saver Lock Time:** To configure the time to make it display sleep screen when it is in screen savor mode.

**Screen Saver:** To enable screen saver mode.

**Screen Lock:** To enable the lock of screen, the device will be unlocked over the sleep time. Users are required the face recognition (Face ID) or password to wake up IT83X.

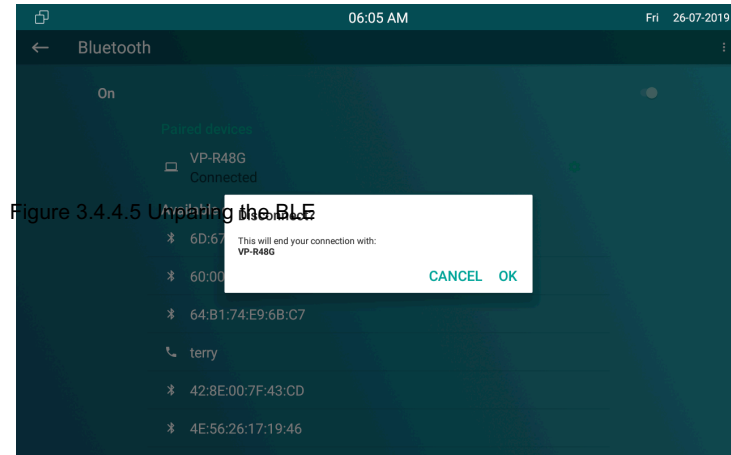



**Screen Clean:** Press screen clean to clean the screen, and it will keep users from misusing.

**Font Size:** To adjust the size of words which is displayed on the screen.

### 3.4.6. Sound Settings

On the device, go to **More - Settings - Sound**.

**Ring Volume:** To set ring volume for incoming calls.

**Talk Volume:** To set talk volume during the call.

**Tone Volume:** To set tone volume.

**Ring Tones:** To set different ring tones for incoming call.

**Notification Sound:** To set notification sound when receiving message.

### 3.4.7. Door Bell Sound

On the web portal, go to **Phone - Audio**.

Figure 3.4.6-1 Doorbell sound

Figure 3.4.5-1 Sound setting

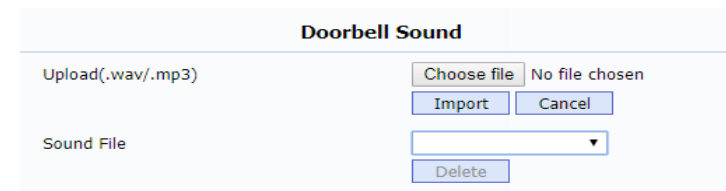
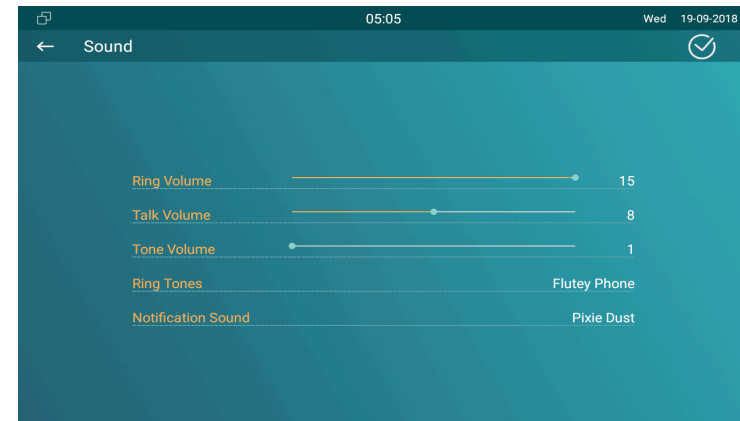

**Upload:** To choose the suitable sound file from the local folder. Click Import to save. Please note the tip about the sound file format.

**Sound File:** Choose one sound file from imported sound files before.

### 3.4.8. DND

The full name of DND is Do Not Disturb. It allows IT83X to ignore any incoming calls.

- On the device home screen, tap the **DND** to able or disable DND function.

On the web portal, go to **Phone - Call feature - DND**.

**DND:** Enable or disable this function.

**Return Code When DND:** To configure the return code to caller when rejecting the call.

**DND On Code:** The code is used to turn on DND on server's side, if

Figure 3.4.7-2 DND setting

Figure 3.4.7-1 DND switch

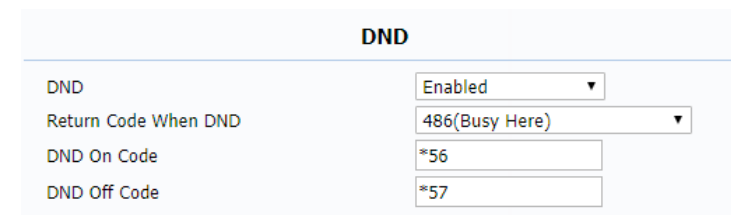
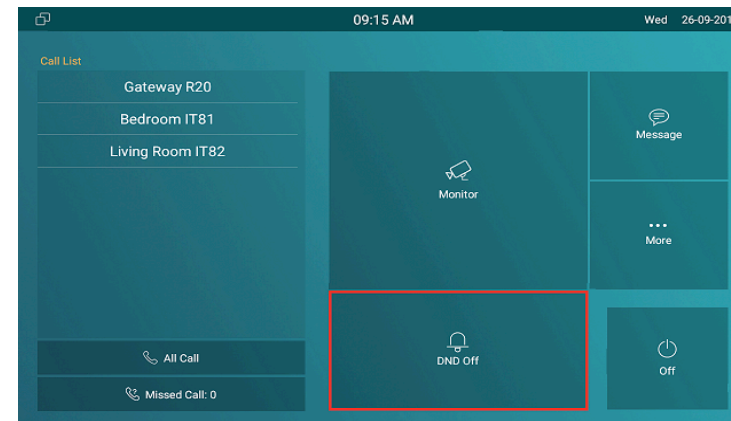

configured, IT83X will send a SIP message to server to turn on DND on server side if users press DND when DND is off.

**DND Off Code:** The code is used to turn off DND on server's side, if configured, IT83X will send a SIP message to server to turn off DND on server side if users press DND when DND is on.

### 3.4.9. Capture

On the device, go to **More - Settings - Call Feature**.

IT83X will automatically take a screenshot from the visitor during the talking, or users can tap the **Capture** key during the live view or calling manually and the capture will be saved in the default path.

Users can change the default path by themselves.

### 3.4.10. Logo

On the web portal, go to **Phone - Logo**.

Figure 3.4.9-1 Boot logo

Figure 3.4.8-1 Capture path

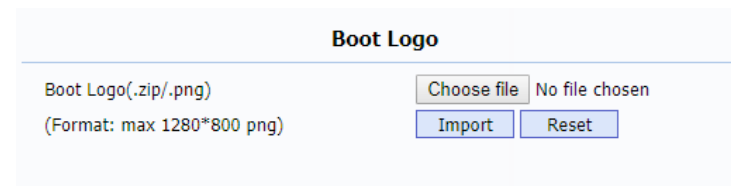

Users are able to upload the logo picture, IT83X will display the logo when powering up.

Click **Reset** to reset the boot logo to original one.

### 3.4.11. Key Set of IT83X Monitor

On the web portal, go to **Phone - Key/Display**. Users can customize the feature icon display, to choose which feature will be shown and where it will be displayed.

**Type:** To select which function shall be displayed on the home page or more page. “DND” and “Message” are displayed on home page, “Call,” “Contact,” “Settings” and “Status” are displayed on more interface by default.

**Value:** To fill in corresponding parameters for some types. For example, if users want to display a third party APP on the home screen, the type shall be chosen as “Custom APK” and fill in the value with corresponding package name and class name.

The screenshot shows two configuration sections: "Home Page Display" and "More Page Display". Each section has a table with columns for "Area", "Type", and "Value".

Area	Type	Value
Area 1	DND	
Area 2	Message	

Figure 3.4.10-1 Icon display

Area	Type	Value
Area 1	Call	
Area 2	Contact	
Area 3	Settings	
Area 4	DND	
Area 5	Arming	
Area 6	SOS	
Area 7	Motion Detector	
Area 8	Custom APK	

**Example:** To view the display example of IT83X on home page interface or more interface.

## 3.5. Local PhoneBook

### 3.5.1. Adding a Contact

On the device, go to **More - Contacts - LocalPhoneBook**.

- Enter Contact interface, and then press **+** symbol ① to add new contact.
- Type in new contact name ② .
- Click **Number 1/2/3** ③ to enter number 1/2/3, which could be SIP number or IP number. It is supported 3 numbers for each of the contact person.
- Click **CameraUrl** ④ to enter RTSP URL of outdoor unit.

**Note:** The RTSP URL of Akuvox door phone is `rtsp://device_IP/live/ch00_0`.

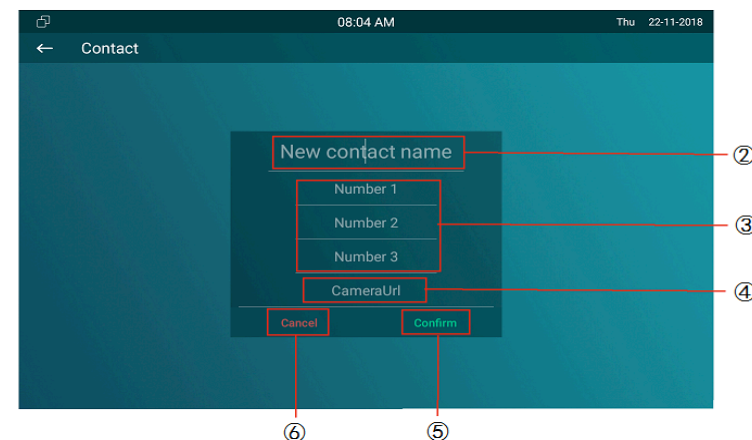
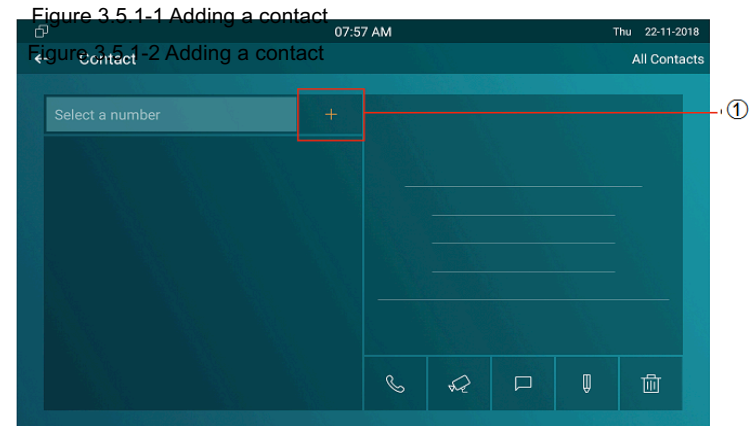

- Tap **Cancel** ⑥ to cancel the operation or press **Confirm** ⑤ to make changes to the contact setting.

### 3.5.2. Editing a Contact

On the device, go to **More - Contacts - Local PhoneBook** to enter contact interface, and select one existed contact.

- Press **Edit** icon ① to modify the existed contact.
- Press **Delete** icon ② to delete a existed contact.

On the web portal **PhoneBook - Local Book**, users can also do some modification about contact.

**Contact:** To display all contact or black list.

**Search:** To search the contact by entering number or name.

**Dial:** To dial out the number that users have filled in.

Figure 3.5.2-2 Web contact

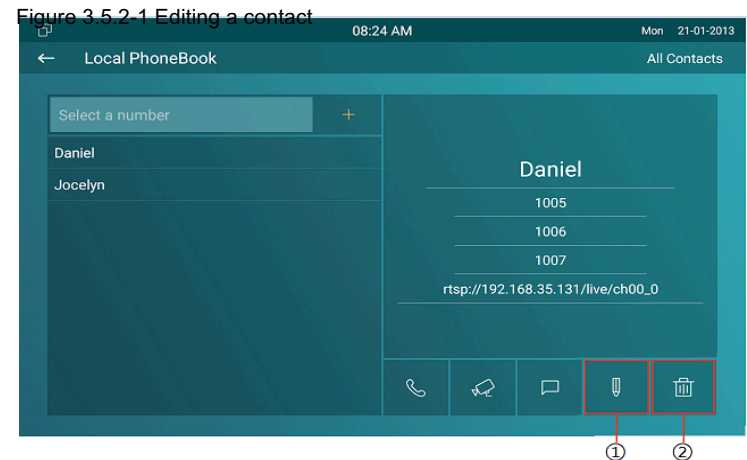

**Local Book**

Contact: All Contacts

Search: [Search] [Reset]

Dial: [Dial] [Hand Up]

Index	Name	Number 1	Number 2	Number 3	Group	
1	Dan..	1005	1006	1007	Default	<input type="checkbox"/>
2	Joc..	1002	192.168.35...	1003	Default	<input type="checkbox"/>
3						<input type="checkbox"/>
4						<input type="checkbox"/>

### 3.5.3. Contact Import/Export

**Import/Export:** To import or export the contacts in bulk, please make sure the format is correct.

Figure 3.5.3-1 Import/Export contact

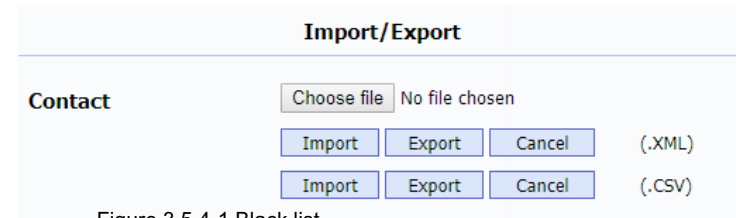

Figure 3.5.4-1 Black list

### 3.5.4. Black List

On the device, go to **More - Contact - LocalPhoneBook - Black List**.

- Click **All Contacts** ① to switch the local phone book from all contacts to black list or vice versa.
- Press **+** ② to add number into black list.
- Click phone book icon ③ to view the existing contacts in local phone book.
- Tap contacts ④ to select the corresponding contact person into black list.



- Tap **Select All** ⑤ to select all contacts.
- Tap **Confirm** ⑥ to add contacts into black list.
- Tap **Cancel** ⑦ to cancel the operation.

On the web portal, **PhoneBook - Local Book - Contact - Blacklist.**

User can also do some configurations.

**Contact:** To display black list or all contact.

**Search:** To search the contact by entering number or name.

**Dial:** To dial out the number that users have filled in.

**BlackList Setting:** To add new contact to black list.

Figure 3.5.4-3 Add blacklist

Index	Name	Number 1	Number 2	Number 3	
1	Joc..	1002	192.168.35...	1003	<input type="checkbox"/>
2					<input type="checkbox"/>
3					<input type="checkbox"/>
4					<input type="checkbox"/>
5					<input type="checkbox"/>
6					<input type="checkbox"/>
7					<input type="checkbox"/>
8					<input type="checkbox"/>
9					<input type="checkbox"/>
10					<input type="checkbox"/>

**BlackList Setting**

Name:

Number 1:

Number 2:

Number 3:



## 3.6. Intercom Call

### 3.6.1. IP Direct Call

Without sip server, users can also use IP address to call each other, but this way is only suitable in the LAN.

On the web portal, go to **Phone - Call Feature - Others - Direct IP** to enable the direct IP function.

Enter the IP address of the caller, and then press **Audio Call** or **Video Call** to make a call.

### 3.6.2. SIP Call

Sip call uses sip number to call each other which should be supported by sip server. Users need to register an account and fill some sip feature parameters before using it.

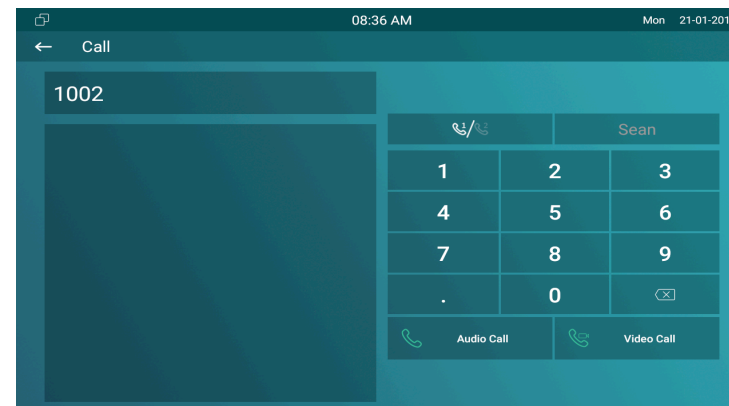
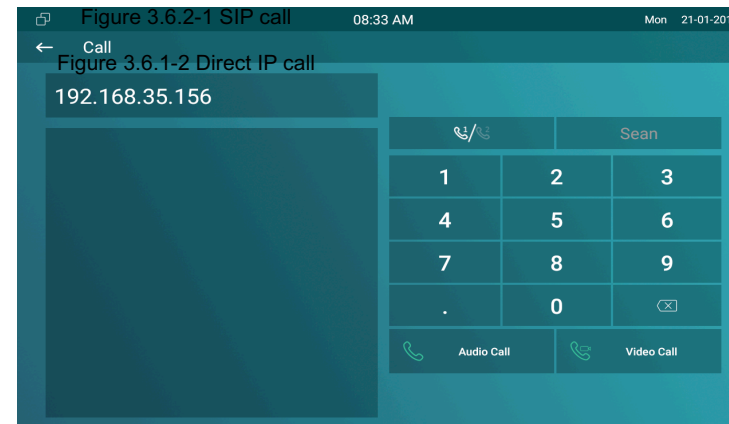
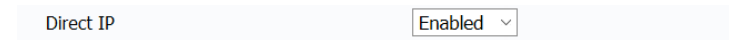

### 3.6.3. Account Status

On the device, go to **More - System Info - Account**.

Users could check the basic SIP account status here, registered means it is ready for using.

On the web portal, go to **Status - Account** information to check the basic information of SIP account.

Figure 3.6.3-2 Account info

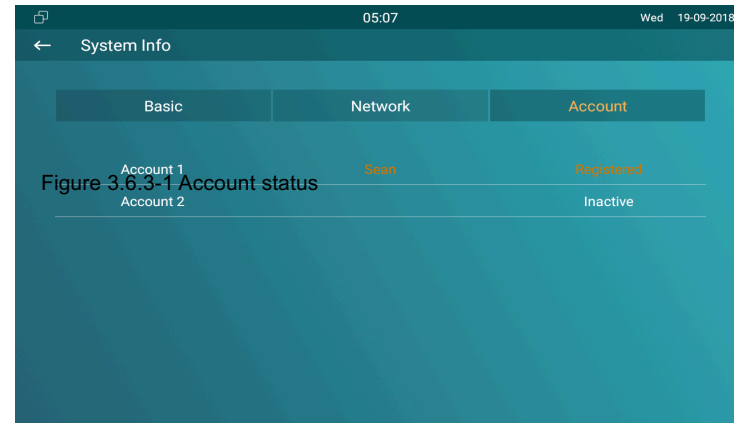

Account Information	
Account1	1004@192.168.35.230 Registered
Account2	None@None Disabled

### 3.6.4. SIP Account

On the device, go to **More - Settings - More - Account**.

**Active:** To activate SIP account.

**Label:** To enter the label name of this account, which will show on the account status interface.

**Display Name:** To enter the display name of this account, which will show on other devices when making calls.

**Register Name:** To enter the number registered onto SIP server.

**User Name:** To enter the extension number registered onto SIP server.

**Password:** To enter the password of the corresponding users.

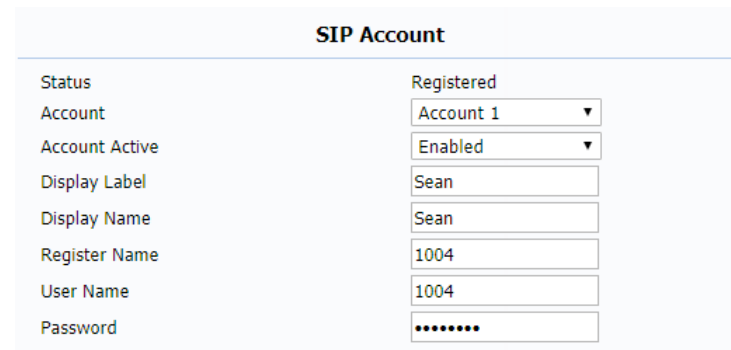
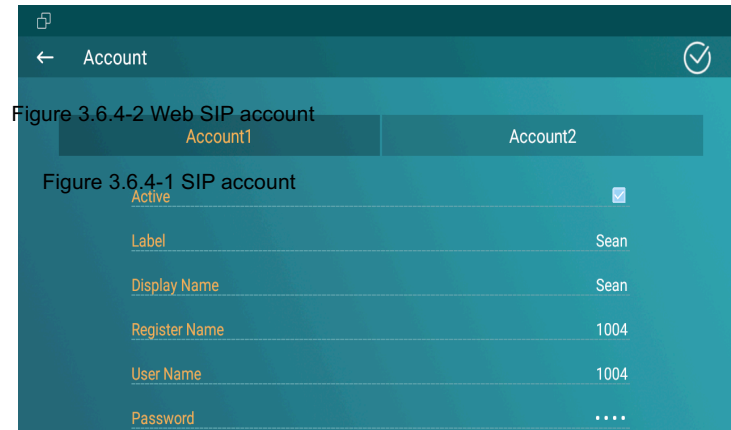

Figure 3.6.5-2 SIP server

### 3.6.5. SIP Server

Enter the SIP account address which points to the sip server.

**Server IP:** To enter SIP server's IP address or URL.

**Port:** The specified port number for the sip server.

**Registration Period:** The registration will expire after registration period, and IT83X will re-register automatically within registration period.

On the web portal, go to **Account - Basic** to check the information of SIP account in details.

### 3.6.6. Outbound Proxy Server

On the web portal, go to **Account - Basic** to setup outbound proxy server.

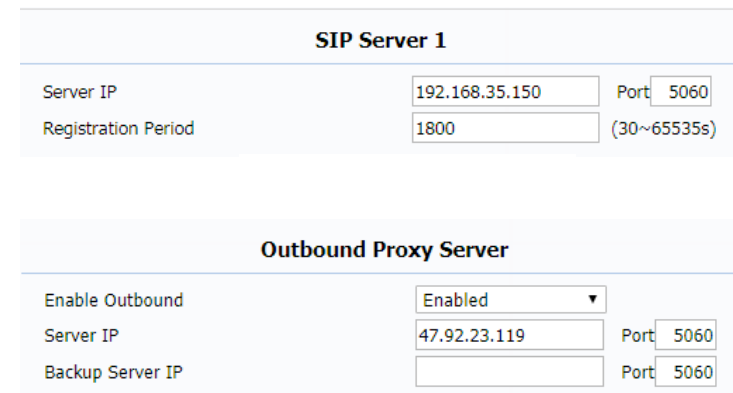
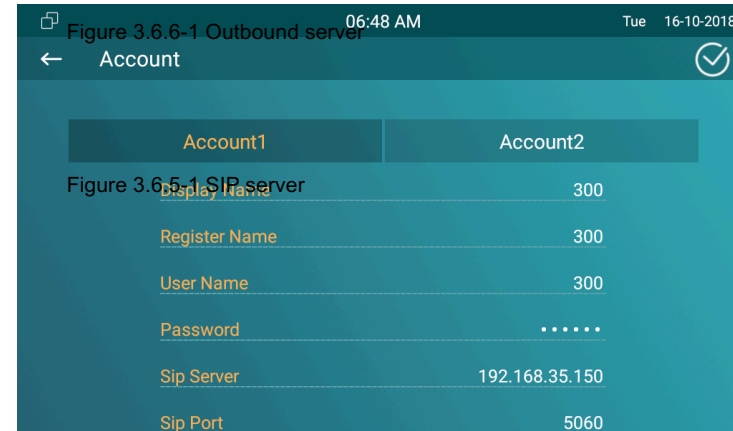

**Outbound Proxy Server:** To configure the proxy server to receive all initiating request messages and route them to the designated SIP server.

### 3.6.7. Transport Type

On the web portal, go to **Account - Basic** to setup transport type.

- UDP: UDP is an unreliable but very efficient transport layer protocol.
- TCP: Reliable but less-efficient transport layer protocol.
- TLS: Secured and reliable transport layer protocol.
- DNS-SRV: DNS record for specifying the location of services

### 3.6.8. Auto answer

On the web portal, go to **Account - Advanced** to enable /disable auto answer feature. It will auto answer all incoming calls if it is enabled.

Transport Type	
Transport Type	UDP ▼

Call	
Max Local SIP Port	5062 (1024~65535)
Min Local SIP Port	5062 (1024~65535)
Auto Answer	Disabled ▼
PTime	20 ▼
Prevent SIP Hacking	Disabled ▼

Figure 3.6.8-2 Whitelist setting

**Note:** Auto answer is only available with SIP accounts.

On the web portal, go to **Phone - Call Feature** to setup auto answer whitelist. It will auto answer the incoming calls when the caller is in white list.

**Device Location:** To enter the device name /location.

**SIP/IP:** To enter the SIP /IP number of the corresponding devices.

**Auto Answer WhiteList:** To display the SIP /IP number stored in IT83X's white list.

**Note:** White list takes effect both SIP account and IP address.

### 3.6.9. Assistance call

Assistance call is used to call out the emergency numbers in loop times when users need help. Users could choose to display SOS on the home /more page, please refer to chapter 3.4.10 about the feature display setting.

**Auto Answer WhiteList**

Index	Device Location	SIP/IP
1	Lobby R29S	1006

Figure 3.6.10-1 Multicast group

**Call Number:** To setup 3 SOS numbers. Once users press SOS key on the home page (SOS display key shall be set on the web manually), IT83X will call out the number in order.

**Call Timeout:** Setup the timeout for each number. Once users call out, if the other side will not answer within the timeout, IT83X will continue to call the next number.

**Loop Times:** To setup the call loop times.

### 3.6.10. Multicast

Multicast function could only be applied among indoor monitors. After configuration on the web portal, users could tap **All Call** on the home page of the device to make a call.

On the web portal, go to **Phone - Multicast**.

**Multicast Setting:** To set the IT83X in one of the groups or disable this function.

Figure 3.6.10-2 Multicast address setting

**Multicast Setting**

---

Multicast Group

Listen List		
Listen Group	Listen Address	Label
Multicast List 1	<input type="text" value="224.1.6.11:51230"/>	<input type="text" value="Test_All Call"/>
Multicast List 2	<input type="text"/>	<input type="text"/>
Multicast List 3	<input type="text"/>	<input type="text"/>

**Multicast List:** To fill in the parameters of multicast group. IT83X will establish multicast calls to other indoor monitors which are set in multicast group.

**Listen List:** To fill in the parameters of listen group. IT83X will receive multicast calls if some indoor monitors call the listen group.

**Label:** To show the label name on the calling interface if users establish all call.

## 3.7. Security

### 3.7.1. Monitor Settings

Monitor will help users to check real-time video of the surrounding environment of house. In the device, go to **More - Settings - More - Monitor**.

Figure 3.6.10-3 Multicast group

Multicast List	
Multicast Group	Multicast Address
Multicast Group 1	224.1.6.11:51230
Multicast Group 2	224.1.6.11:51231
Multicast Group 3	224.1.6.11:51232

Figure 3.7.1-1 Live view

The screenshot shows a mobile application interface for 'Monitor' settings. The title bar is dark teal with a back arrow on the left and a checkmark on the right. Below the title bar, there are five input fields with labels and values:

- Number:** 1006
- Doorphone ID:** 001
- RTSP Address:** rtsp://192.168.35.131/live/ch00\_0
- User Name:** admin
- Password:** .....



**Number:** To enter the IP address/SIP number of the corresponding camera. Enter the RTSP or ONVIF URL of the door phone or IP camera.

**Doorphone ID/Device Name:** To enter the ID number of doorphone, which could be set by users.

**RTSP Address/Destination URL:** To set the RTSP URL for the door phone. The RTSP format of Akuvox door phone is **rtsp://device IP/live/ch00\_0**.

**User Name:** To enter the user name if required.

**Password:** To enter the password if required.

On the web portal **Phone - Monitor**, users can also setup the monitor information.

## AKUVOX

Figure 3.7.1-2 Live view in web

Figure 3.9.2-1 Face ID

Figure	1007
Device Name	Gateway R26
Destination URL	rtsp://192.168.35.121/
User Name	admin
Password	.....

**Door Phone**

Index	Number	Name	URL	User Name	
1	1007	Gateway R26	rtsp://192.168.35.121/live/ch00_0	admin	<input type="checkbox"/>



## 3.8. Access control

### 3.8.1. Face ID

On the device, go to **More - Settings - More - Face ID** to setup face ID to access to IT83X, which provides setting security.

- To implement face ID feature on IT83X, the **Screen Lock** on display setting interface should be enabled first.
- The whole process is actually self-explanatory, follow the indication to record users' face ID to IT83X.
- When screen lock is enabled, users could choose face ID or password (System code) to enter IT83X.

### 3.8.2. Local Relay

IT83X has NO/NC/COM three terminals which supports to connect locks by itself.

Figure 3.8.2-1 Local relay setting

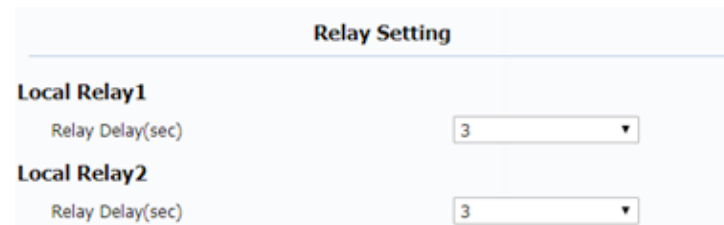

The screenshot shows a 'Relay Setting' interface with two sections: 'Local Relay1' and 'Local Relay2'. Each section has a 'Relay Delay(sec)' label and a dropdown menu. Both dropdown menus are currently set to '3'.

Relay Setting	
<b>Local Relay1</b>	
Relay Delay(sec)	3 ▼
<b>Local Relay2</b>	
Relay Delay(sec)	3 ▼

Go to **Phone - Relay** to setup the DTMF code of local relay in website. Users can press the **Unlock** key during the call.

**Relay Delay:** To set the delay time for local relay.

**Status:** To enable or disable the softkey in talking page.

**Display Name:** To modify the display name of unlock icons in talking page.

**Relay:** To set the relay type, including local relay 1/2, remote relay HTTP and remote relay DTMF.

### 3.8.3. Remote relay

IT83X can use the unlock key during the call to open the door in doorphone's site. Users need to setup the same DTMF code in the door phone and indoor monitor.

**Remote Relay:** To set DTMF code for remote relay, which is “#” by default.

Figure 3.8.3-1 Remote relay setting

Figure 3.8.2-2 Relay display

Softkey In Talking Page			
	Status	Display Name	Relay
Key 0	Enabled ▾	Unlock1	Local Relay 1 ▾
Key 1	Enabled ▾	Unlock2	Local Relay 2 ▾
Key 2	Enabled ▾	Unlock3	Remote Relay DTMF ▾

Figure 3.8.4-1 Reboot

**Remote Relay**

DTMF code

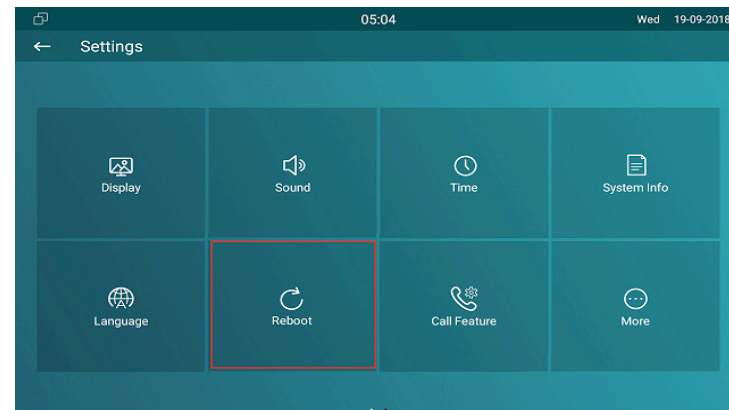

### 3.8.4. Reboot

On the device, go to **More - Settings - Reboot**.

- Click the **Reboot** icon to reboot the device.

One the web portal **Upgrade - Basic - Reboot**, users can also reboot the device.

Figure 3.8.5-1 Reset

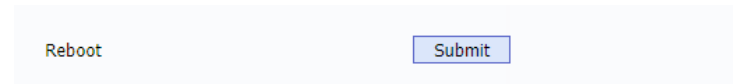

### 3.8.5. Reset

On the device, go to **More - Settings - More**.

**Reset To Factory Setting:** Reset all data to factory settings.

**Reset Config To Factory Setting:** Reset all configurations (in the directory /data/data/config) which only be used by IT83X to factory settings. But like 3rd party application which users installed, contacts which users added, such kind of data will not be reset.

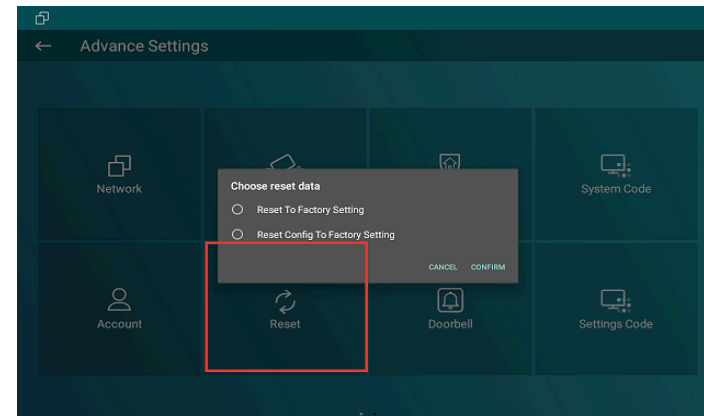
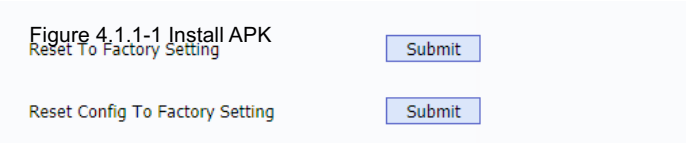

Figure 3.8.5-2 Web reboot

On the web portal **Upgrade - Basic**, users can also store the device.



## 4. Advanced Features

### 4.1. Phone Configuration

#### 4.1.1. Installing Custom APK

Users could choose to display **Custom APK** (The 3rd party Android app) on the home/more page, which provides users easier access

Third Party APK Control	
Package Name	<input type="text"/>
APP Class Name	<input type="text"/>
Start Up Enable	Disabled ▼
Turn Back Apk Enable	Disabled ▼
Intervals Without Operating	10 ▼ (s)
Show App Icon	Enabled ▼

to their own application. On the web portal, go to **Upgrade - Key/Display**.

**Package Name:** To fill in the package name of APK (For example: com.akuvox.mobile.smartplus).

**APP Class Name:** To fill in the class name of APK (For example: com.akuvox.mobile.module.main.view.SplashActivity).

**Start Up Enable:** To choose whether APK should start up automatically when power up.

**Turn Back Apk Enable:** To choose whether turn back APK without operating for some interval.

**Intervals Without Operating:** To choose how much time to turn back APK without operating.

**Show App Icon:** To choose whether to show APP icon on the home interface or not.

## 4.1.2. Discovery setting

If **Discovery** mode is adopted, users don't need to configure the devices by themselves. IT83X will scan automatically all types of the devices on the same discovery node.

On the device, go to **More - Settings - More** to configure the discovery mode and location name. **Discovery Node/Device Address:** To indicate the locations of the device (For example, device address 1.1.1.1.1 means that this device is located in Community 1, Building 1, Unit 1, Floor 1, Room 1).

**Discovery Extension/Device Extension:** To display the extension number of the device.

**Location/Device Location:** To enter the name/location to distinguish devices from each other.

On the web portal **Network - Advanced**, users can also make changes to the device connecting node.

Figure 4.1.2-2 Discovery setting in web

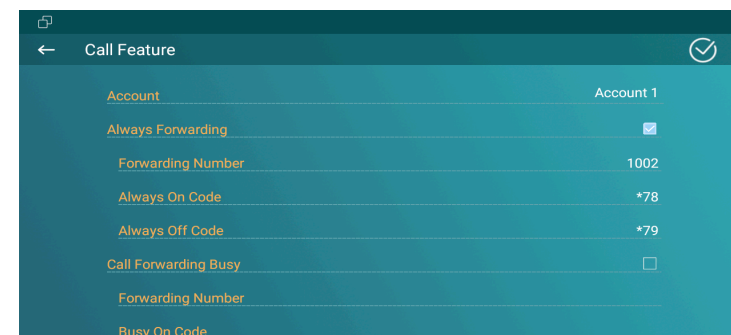
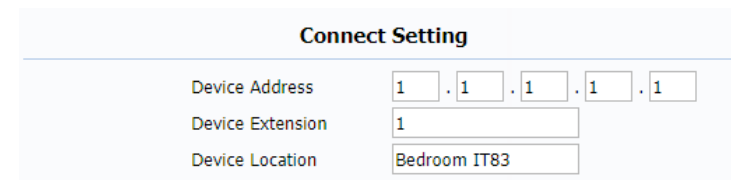
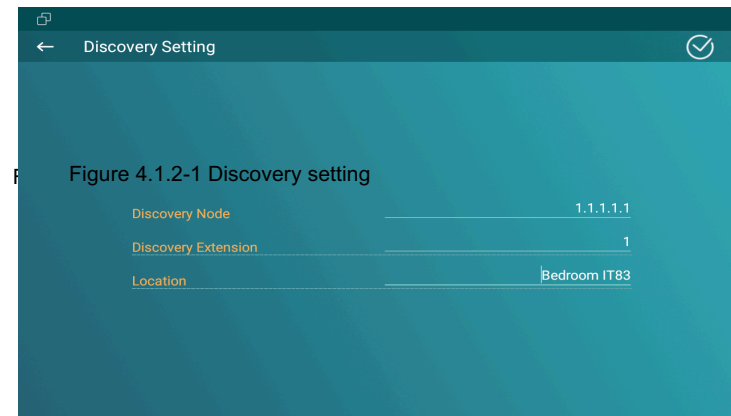

## 4.2. Intercom

### 4.2.1. Call Forwarding

On the device, go to **More - Settings - Call Feature**.

**Account:** To choose which account shall implement call forwarding feature.

**Always forward:** All the incoming calls will be forwarded unconditionally to a specified number.

**Busy Forward:** The incoming calls will be forwarded to a specified number when IT83X is busy.

**No answer Forward:** The incoming calls will be forwarded to a specified number when the ring tone is time out without answering.

**Always/Busy/No answer Forward:** Tick which forward users want to setup.

**Forwarding Number:** Enter the target numbers which users want to forward.

Figure 4.2.1-2 Web Forward

Forward Transfer	
Always Forward	Disabled ▼
Target Number	1002
Busy Forward	Enabled ▼
Target Number	1007
No Answer Forward	Disabled ▼
No Answer Ring Time	30 ▼
Target Number	1008



**On/off Code:** The code used to turn on/off forward feature on server's side, if configured, IT83X will send a sip message to server to turn on/off forward feature on server side if users press forward when forward feature is off/on.

On the web portal, go to **Phone - Call Feature**, users can also setup it.

## 4.2.2. Intercom

**Intercom:** To allow users establishing a call directly with the callee.

**Active:** To enable or disable Intercom function.

**Intercom Mute:** To eliminate the voice of the callee if enabled.

**Intercom Preview:** To enable preview function.

## 4.2.3. Subscribe

On the web portal, go to **Account - Advanced - Subscribe**.

**Subscribe:** To display and configure MWI, subscription settings.

Figure 4.2.2-1 Intercom

Figure 4.2.3-1 Subscribe

Intercom	
Active	Enabled ▼
Intercom Mute	Disabled ▼
Intercom Preview	Disabled ▼

Subscribe	
MWI Subscribe	Enabled ▼
MWI Subscribe Period	1800 (120~65535s)
Voice Mail Number	1004

**MWI Subscribe:** To enable or disable message waiting indicator function.

**MWI Subscribe Period:** To setup the time of MWI function.

**Voice Mail Number:** To fill in the voice mail number.

### 4.2.4. Audio Codec

On the web portal, go to **Account - Advanced**.

**Audio Codecs:** To configure the disabled codecs and enabled codecs by pressing the corresponding buttons. Codec means coder-decoder which is used to transfer analog signal to digital signal or vice versa.

### 4.2.5. Video Codec

On the web portal, go to **Account - Advanced**.

**Video Codec:** To configure the disabled codecs and enabled codecs by pressing the corresponding buttons.

Figure 4.2.4-1 Audio codes

Figure 4.2.5-1 Video codec

The screenshot shows the configuration interface for codecs, divided into three sections: Audio Codecs, Video Codecs, and Video Codec details.

**Audio Codecs:** This section contains two lists. The 'Disabled Codecs' list includes ILBC\_13\_3, ILBC\_15\_2, OPUS, and L16. The 'Enabled Codecs' list includes PCMU, PCMA, G729, and G722. There are '>>' and '<<' buttons between the lists, and up/down arrow buttons next to the 'Enabled Codecs' list.

**Video Codecs:** This section contains two lists. The 'Disabled Codecs' list includes H265. The 'Enabled Codecs' list includes H264 and H263. There are '>>' and '<<' buttons between the lists, and up/down arrow buttons next to the 'Enabled Codecs' list.

**Video Codec:** This section is a table with two columns for H263 and H264. The rows are Codec Name, Codec Resolution, Codec Bitrate, and Codec Payload.

	H263	H264
Codec Name	H263	H264
Codec Resolution	CIF	CIF
Codec Bitrate	320	320
Codec Payload	34	104

**Codec Resolution:** To adjust the resolutions for different video codecs.

**Codec Bitrate:** To adjust the bitrate for different video codecs.

**Codec Payload:** To adjust the codec payload for video codec.

## 4.2.6. NAT

On the web portal, go to **Account - Advanced**.

**UDP Keep Alive Message:** To send UDP keep alive message periodically to router to keep NAT port alive if enabled.

**UDP Alive Msg Interval:** To Keep alive message interval.

**RPort (Remote Port):** To add remote port in to outgoing SIP message for designated account if enabled.

## 4.2.7. User Agent

On the web portal, go to **Account - Advanced**.

Figure 4.2.7-1 User agent

Figure 4.2.6-1 NAT

NAT	
UDP Keep Alive Messages	Enabled ▾
UDP Alive Msg Interval	30 (5~60s)
RPort	Disabled ▾

User Agent	
User Agent	Akuvox

**User Agent:** To customize user agent field in the SIP message. If user agent is set to specific value, users could see the information from SIP message. If user agent is not set by default, users could see the company name, model number and firmware version from SIP message.

## 4.2.8. DTMF

On the web portal, go to **Account - Advanced**.

**DTMF:** To configure RTP audio video profile for DTMF and its payload type.

**Type:** Support Inband, Info, RFC2833 or their combination.

**How To Notify DTMF:** Only available when DTMF Type is Info.

**DTMF Payload:** To configure payload type for DTMF.

## 4.2.9. Encryption

On the web portal, go to **Account - Advanced**.

Figure 4.2.9-1 Encryption

Figure 4.2.8-1 DTMF

DTMF	
Type	<input type="text" value="Info"/>
How To Notify DTMF	<input type="text" value="DTMF-Relay"/>
DTMF Payload	<input type="text" value="101"/> (96~127)

Encryption	
Voice Encryption(SRTP)	<input type="text" value="Compulsory"/>

**Voice Encryption(SRTP):** If enabled, all audio signal (It's RTP streams indeed) will be encrypted for more security.

## 4.2.10. Call Related

**Max/Min Local Sip Port:** To configure maximum /minimum local SIP port for designated account.

**PTime:** Interval time between two consecutive RTP packets.

**Prevent SIP Hacking:** Enable to prevent SIP from hacking in the Internet.

## 4.2.11. Remote Control

On the web portal, go to **Phone - Call feature**.

**Remote Control** could allow specific host to interact with IT83X by sending HTTP or HTTPS requests. The specific action could be answering an incoming call, hangup an ongoing call and so on.

Call		
Max Local SIP Port	<input type="text" value="5062"/>	(1024~65535)
Min Local SIP Port	<input type="text" value="5062"/>	(1024~65535)
Auto Answer	<input type="text" value="Disabled"/>	▼
PTime	<input type="text" value="20"/>	▼
Prevent SIP Hacking	<input type="text" value="Disabled"/>	▼

Remote Control	
Allowed Access IP List	<input type="text" value="192.168.35.115"/>

Figure 4.2.12-1 Session time out  
Figure 4.3.1-1 Web relay

**Allowed Access IP List:** To configure the IP address of allowed host.

## 4.2.12. Session Time Out

**Session Time Out:** To set the time out value, the ongoing call will be disconnected automatically if session time out.

Session Time Out	
Session Time Out Value	<input type="text" value="300"/> (60~14400s)

## 4.3. Access Control

### 4.3.1. Web Relay

On the web portal, go to **Phone - Relay - Webrelay**.

**IP Address:** To fill in the IP address of web relay.

**UserName:** To fill in the user name of the web relay.

**Password:** To fill in the password of the web relay.

Web Relay	
IP Address	<input type="text" value="192.168.35.123"/>
UserName	<input type="text" value="admin"/>
Password	<input type="password" value="....."/>

### 4.3.2. Remote Relay by HTTP

On the web portal, go to **Phone - Relay**.

**Remote Relay By HTTP:** To configure the parameters to trigger a certain remote relay of door phone by sending http message, which also requires the configurations on door phone.

Figure 3.9-1 Remote relay by HTTP

Index	IP	UserName	Password	<input type="checkbox"/>
01	<input type="text"/>	<input type="text"/>	<input type="text"/>	<input type="checkbox"/>
02	<input type="text"/>	<input type="text"/>	<input type="text"/>	<input type="checkbox"/>

Figure 4.4.1-1 Zone setting

## 4.4. Security

### 4.4.1. Arming Zone Setting

On the device, go to **More - Settings - More - Arming**.

Arming function is very useful for home safety. IT83X supports 8 zones to connect different alarm detection devices for different zones. IT83X does not provide the power for detection devices, connecting the GND and IOX terminal (For example, enable the zone 1, users need to connect IO1 and GND).

08:14 AM Mon 21-01-2013

Zone Settings

Zone parameter settings

Location	Guest room
Type	Doorbell
Trigger Mode	NO
Alarm Status	24H
Doorbell ring	Andromeda
Alarm Volume	1
Alarm Time	60 s

- Zone1
- Zone2
- Zone3
- Zone4
- Zone5
- Zone6
- Zone7
- Zone8

**Location:** To select which location the detection device is in, including Bedroom, Guest room, Hall, Window, Balcony, Kitchen, Study and Bathroom.

**Type:** To select which type of detection device is, including Infrared, Dmagnet, Smoke, Gas and Urgency..

**Trigger Mode:** To setup triggering mode for the sensor, including NO (normal open) and NC (normal closed).

**Alarm Status:** To setup status of alarm sensor, including enable, disable and 24H.

**Note:** Disable status of detector means it cannot be triggered, 24H status means it cannot be disabled. Enable status means it depends on arming mode.

## 4.4.2. Motion Detector

Users could choose to display **Motion Detector** on the home/more page, please refer to chapter 3.4.10. IT83X could

Figure 4.4.2-1 Motion detection

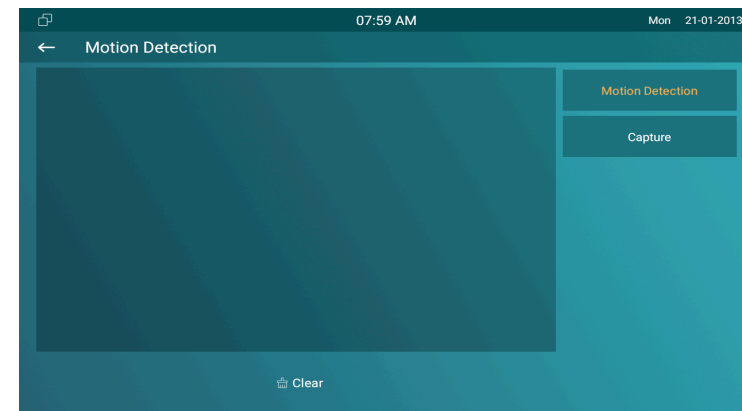



receive the captured motion pictures from the door phone, which requires the configurations on door phone.

## 4.5. Upgrade

### 4.5.1. Basic Upgrade

On the web portal, go to **Upgrade - Basic**.

**Firmware Version:** To display the firmware version at present.

**Hardware Version:** To display the hardware version at present.

**Upgrade:** To select the upgrading file from PC manually.

**Submit:** To submit the upgrading file to IT83X.

**Cancel:** To cancel submitting the upgrading file.

Figure 4.5.1-1 Basic upgrade

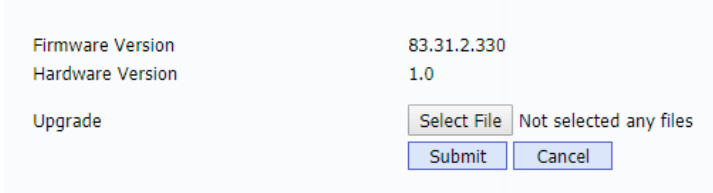

The screenshot shows a web portal interface for the 'Basic Upgrade' section. It displays the current 'Firmware Version' as 83.31.2.330 and the 'Hardware Version' as 1.0. Below this information, there is an 'Upgrade' section with a 'Select File' button and the text 'Not selected any files'. At the bottom of the 'Upgrade' section, there are two buttons: 'Submit' and 'Cancel'.

Firmware Version	83.31.2.330
Hardware Version	1.0
Upgrade	<input type="button" value="Select File"/> Not selected any files
	<input type="button" value="Submit"/> <input type="button" value="Cancel"/>

Figure 4.5.2.1-1 PNP Option

## 4.5.2. Autop

Autop (Auto-Provisioning), this feature is used to configure or upgrade IT83X in batch via the support of third party servers.

To use DHCP/PNP/TFTP/FTP/HTTP/HTTPS servers to get URL, and then download firmware and/or its corresponding configuration files from servers. These configuration files and firmware will be used to update firmware and the corresponding parameters on the phone.

### 4.5.2.1. PNP Autop

**PNP (Plug and Play):** To enable or disable Plug and Play feature, which will send SIP subscription message to PNP server automatically to get auto provisioning server's address if enabled. By default, this SIP message is sent to multicast address 224.0.1.75 (PNP server address by standard).

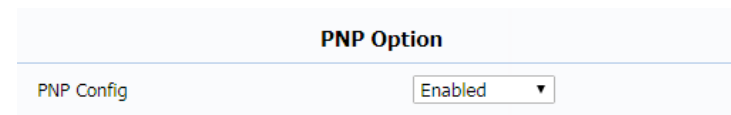

### 4.5.2.2. DHCP Autop

**DHCP Option:** To use designated DHCP option to get auto provisioning server's address via DHCP.

### 4.5.2.3. Manual Autop

**Manual Autop:** To display and configure manual update server's settings.

**URL:** To fill in the Auto provisioning server address.

**User Name:** To fill in the user name if server needs an username to access, otherwise left blank.

**Password:** To fill in the password if server needs a password to access, otherwise left blank.

**Common AES Key:** To decipher common auto provisioning configuration file for IT83X.

Figure 4.5.2.2-1 DHCP option  
Figure 4.5.2.3-1 Manual autop

The screenshot shows a configuration interface with two main sections: 'DHCP Option' and 'Manual Autop'.  
In the 'DHCP Option' section, there is a 'Custom Option' field with the value '129' and a range '(128~254)'. Below it, 'DHCP Option Enable' is checked, and 'Option 43' and 'Option 66' are also checked.  
The 'Manual Autop' section contains several fields: 'URL' with the value 'tftp://192.168.35.115', 'User Name' with 'admin', 'Password' with masked characters '\*\*\*\*\*', 'Common AES Key' with masked characters '\*\*\*\*\*', and 'AES Key(MAC)' with masked characters '\*\*\*\*\*'. At the bottom of this section is a button labeled 'AutoP Immediately'.

**AES Key (MAC):** Used for IP phone to decipher MAC-oriented auto provisioning configuration file (For example, file name could be 0C1105888888.cfg if IT83X’s MAC address is 0C1105888888).

**Notes:** AES is one of many encryption, it should be configured only when configure file is ciphered with AES, otherwise left blank.

#### 4.5.2.4. Automatic Autop

**Automatic Autop:** To display and configure auto provisioning mode settings. It is actually self-explanatory. For example, mode “Power on” means IT83X will go to do provisioning every time it powers on.

**Note:** Please check more details in autop feature guide .

Figure 4.5.2.4-1 Automatic autop

Figure 4.6.1-1 Call log

Index	Type	Date	Time	Local Identity	Name	Number	
1	Received	2018-09-19	04:59:49	192.168.35.2 41@192.168.35.241	Jocelyn	<a href="#">192.168.35.2</a> <a href="#">05@192.168.35.205</a>	<input type="checkbox"/>
2	Missed	2018-09-19	04:59:09	192.168.35.2 41@192.168.35.241	Jocelyn	<a href="#">192.168.35.2</a> <a href="#">05@192.168.35.205</a>	<input type="checkbox"/>
3	Dialed	2018-09-19	04:49:56	192.168.35.2 41@192.168.35.241	Jocelyn	<a href="#">192.168.35.2</a> <a href="#">05@192.168.35.205</a>	<input type="checkbox"/>
4	Dialed	2018-09-19	04:44:34	1004@192.168.35.230:5060	Daniel	<a href="#">1006@192.168.35.230:5060</a>	<input type="checkbox"/>
5	Dialed	2018-09-19	04:44:28	1004@192.168.35.230:5060	Daniel	<a href="#">1006@192.168.35.230:5060</a>	<input type="checkbox"/>
6	Dialed	2018-09-19	04:43:27	1004@192.168.35.230:5060	Daniel	<a href="#">1006@192.168.35.230:5060</a>	<input type="checkbox"/>
7	Dialed	2018-09-19	04:42:58	1004@192.168.35.230:5060	Daniel	<a href="#">1006@192.168.35.230:5060</a>	<input type="checkbox"/>

Figure 4.6.2-1 System log

## 4.6. Logs

### 4.6.1. Call log

On the web portal, go to **PhoneBook - Call Log**. Users are able to view all /dialed /received /missed /forwarded calls.

**Call History:** To select which kind of calls users want to view, including dialed, received, missed and forwarded.

**Export:** To export the call log.

### 4.6.2. System Log

On the web portal, go to **Upgrade - Advanced**. System log provides a professional method for administrator to debug .

**System Log:** To display system log level and export system log file.

**Log level:** To adjust the system log level, which ranges from 0 to 7 and it is 3 by default. The higher level means the more specific system log is saved to a temporary file.

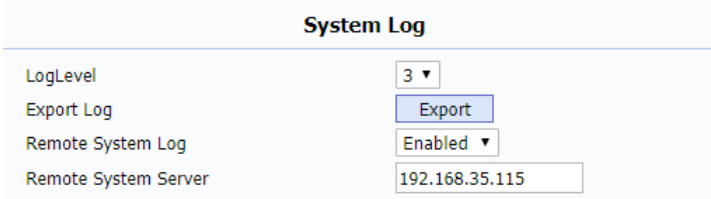

The screenshot shows the 'System Log' configuration page. It contains four settings:

System Log	
LogLevel	3 ▼
Export Log	Export
Remote System Log	Enabled ▼
Remote System Server	192.168.35.115

Figure 4.6.3-1 PCAP

**Export Log:** To export temporary system log file to local PC.

**Remote System Log:** To enable/disable remote system Log.

**Remote System Server:** To input the syslog server address.

### 4.6.3. PCAP

On the web portal, go to **Upgrade - Advanced - PCAP**. PCAP is a network packet capture tool in IT83X itself, which provides an efficient method to troubleshoot network problems.

**PCAP Start:** To start PCAP if users click **Start** button.

**PCAP Stop:** To stop PCAP if users click **Stop** button.

**Export:** To export the PCAP after capturing of packets.

**PCAP Auto Refresh:** To enable or disable PCAP auto refresh.

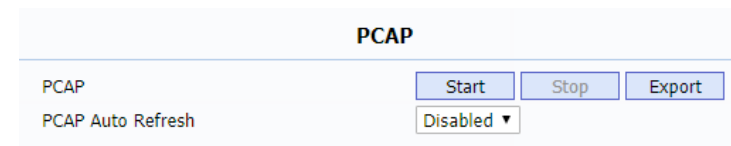

**ACS:** Auto Configuration Server

**Auto:** Automatically

**IT83X**

**AEC:** Configurable Acoustic and Line Echo Cancelers  
Admin Guide

**ACD:** Automatic Call Distribution

**Autop:** Automatic Provisioning

**AES:** Advanced Encryption Standard

**BLF:** Busy Lamp Field

**COM:** Common

**CPE:** Customer Premise Equipment

**CWMP:** CPE WAN Management Protocol

**DTMF:** Dual Tone Multi-Frequency

**DHCP:** Dynamic Host Configuration Protocol

**DNS:** Domain Name System

**DND:** Do Not Disturb

**DNS-SRV:** Service record in the Domain Name System

**FTP:** File Transfer Protocol

**GND:** Ground

**HTTP:** Hypertext Transfer Protocol

**HTTPS:** Hypertext Transfer Protocol Secure

**IP:** Internet Protocol

**ID:** Identification

**IR:** Infrared

**LCD:** Liquid Crystal Display

**LED:** Light Emitting Diode

**MAX:** Maximum

**POE:** Power Over Ethernet

**PCMA:** Pulse Code Modulation A-Law

**PCMU:** Pulse Code Modulation  $\mu$ -Law

## Abbreviations

**PCAP:** Packet Capture

**PT83X**ing and Play  
Admin Guide

**RFID:** Radio Frequency Identification

**RTP:** Real-time Transport Protocol

**RTSP:** Real Time Streaming Protocol

**MPEG:** Moving Picture Experts Group

**MWI:** Message Waiting Indicator

**NO:** Normal Opened

**NC:** Normal Connected

**NTP:** Network Time Protocol

**NAT:** Network Address Translation

**NVR:** Network Video Recorder

**ONVIF:** Open Network Video Interface Forum

**SIP:** Session Initiation Protocol

**SNMP:** Simple Network Management Protocol

**STUN:** Session Traversal Utilities for NAT

**SNMP:** Simple Mail Transfer Protocol

**IP:** IP Devices Management Center

Technical Report069

Transmission Control Protocol

Transport Layer Security

Trivial File Transfer Protocol

User Datagram Protocol

Uniform Resource Locator

Virtual Local Area Network

Wand





## Contact us

For more information about the product, please visit us at [www.akuvox.com](http://www.akuvox.com) or feel free to contact us by

Sales email: [sales@akuvox.com](mailto:sales@akuvox.com)

Technical support email: [techsupport@akuvox.com](mailto:techsupport@akuvox.com)

Telephone: +86-592-2133061 ext.7694/8162

**We highly appreciate your feedback about our products.**

